



Journal of the **TEXTILE Association**

VOL. 72

NO.1

MAY - JUNE 2011



Good health makes good business sense

Presenting for the first time in India - Recron[®] FeelFresh fibres & yarns with antimicrobial properties that help retain freshness for hours together.



Sweat and dirt are a part of our daily lives. But it is the growth of bacteria in these moist and unclean environs that causes the odour that we all detest. Recron[®] FeelFresh contains silver ions that destroy these odour causing bacteria and keep the fabric fresh through long hours of use. This unique property makes it perfect for use in active sports wear, intimate wear, home textiles, as well as for garments used in the healthcare industry.

We're confident that this revolutionary fabric will set new paradigms for the apparel industry and also give a fillip to your profits.

Recron[®]
FeelFresh



Innovation Leads Us To THE FUTURE.



● **spectraVISION Nx**
For Colour Matching



● **accuSHRINK 1 Nx**
For Shrinkage



● **sampleCutter Nx**
For GSM



● **countTESTER 1 Nx**
For Yarn Count



● **crockMETER 1 Nx**
For Rubbing Fastness



● **digiWASH 1 Nx**
For Washing Fastness



● **digiTRA Nx**
For Reed / Pick

Paramount Seven Pearls, the (Nx) Next Generation Series of Instruments, are 7 breakthroughs that give you a microscopic view of the quality of the fabric. These world's finest instruments are ergonomically designed, advanced in features and customer friendly, covering up the 7 most important aspects of quality in fabrics.

- Colour matching cabinet • Shrinkage • GSM • Yarn count • Rubbing fastness
- Washing fastness • Construction of the fabrics.



SpectraLUX JuniorTM

World's
 Most Economical
 & Most Advanced
 Colour Matching Cabinet !
 Please Ask for Details.

www.paramountinstruments.com

NATIONAL SALES AND SERVICE CENTRES

Ahmedabad, Bangalore, Bhadhoi, Bhilwara, Calcutta, Chennai, Erode, Hyderabad, Jaipur, Kanpur, Ludhiana, Mumbai, Panipat, Salem, Surat & Tirupur.

INTERNATIONAL SALES AND SERVICE CENTRES

Bangladesh, Canada, Egypt, El-Salvador, Guatemala, Indonesia, Iran, Malaysia, Mauritius, Pakistan, Peru, South Africa, Sri Lanka, Thailand, Venezuela.

Corporate Office : B-3/45, Paschim Vihar, New Delhi - 110 063, INDIA
Telephones : 011-2525 0630, 2528 4129, 2526 3808, 2526 6163
Fax : +91-11-2525 9336, 2528 3571
Sales (24X7) : +91-0 999 999 1080, 0 999 999 0 999
Customer Care (24X7) : +91-0 999 999 4477, 0 999 999 0 999
E-mail : sales@paramountinstruments.com
Website : www.paramountinstruments.com

An ISO 14001 : 2004 Group - WE CARE FOR OUR ENVIRONMENT !



Natural fiber brands

Lenzing unites three fiber generations under one roof. TENCEL® is convincing with excellent moisture management, reduced bacterial growth and the very best climate and skin properties. Like no other fiber, Lenzing Modal® has stood for pure softness on the skin for more than 40 years. ProModal®, the perfect combination of Lenzing Modal® and TENCEL®, unites softness and functionality. Classical Viscose® sets the quality standard in the textile industry. Lenzing FR®, the flame resistant special fiber, offers protection from heat in various applications.

INDIA OFFICE

Lenzing AG - India

1st Floor, Rajnarayan Towers

70, Race Course

Coimbatore - 641018 Tamilnadu, India

Phone : +91(0) 422 4292800

Fax : +91(0) 422 4292814

www.lenzing.com/textilefibers

Testing equipment for fibres, yarns, and fabrics

STATIMAT DS

automatic tensile, evenness and count tester for yarns.

STATIMAT 4U

automatic tensile tester for high-tenacity yarns and monofilaments, with integrated yarn count measurement module AUTOCOUNT.

DYNAFIL ME

universal filament yarn tester, with automatic package changer model SE or SM.

TEXTURMAT ME+

automatic crimp contraction and shrinkage tester for DTY and other yarn types.

FAVIMAT+ ROBOT2

and -**AIROBOT2**
automatic linear density, crimp and tensile tester for single fibres.

FAVIGRAPH

single fibre linear density and tensile tester.

HELFI

single fibre shrinkage tester.

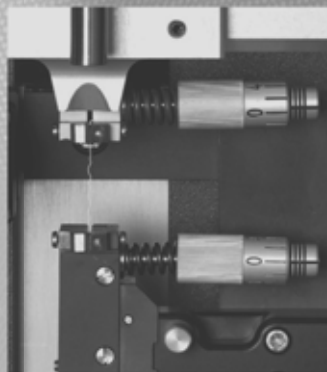
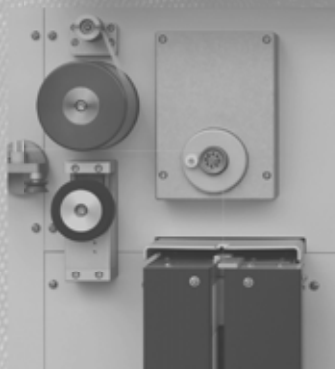

STATIMAT MEL+

automatic tensile tester for elastane yarns (Spandex), elastic combination yarns and elastic fabrics.

STATIMAT ME+

automatic tensile tester for yarns.

COVAFIL

capacitive evenness tester for filament yarns.

COMCOUNT

automatic yarn count measurement module.

FIBRESTRESS

bending-abrasion and cyclic stress tester for fibres and yarns.

FIBROTEST

fibre length- and strength tester.

LENGTHCONTROL LCT

fully automated fibre length tester.

Sole Agents in India: M/s. World Traders MFG. Co.

1413, Maker Chambers V, 13th Floor, Nariman Point, Mumbai 400 021;
Tel.: 91-22-2261 2743, 2284 3423, 2287 2935; Fax: 91-22-22872534;
E-Mail: info@wtmcindia.com

Delhi Office: Ph. No. 91-11-24333256, 24334457;

Chennai: Ph. No. 91-44-24321547, 24338767;

Service Centre: Vashi Ph. No. 91-22-27892948;

Corporate Office: 710. Maker Chambers V, Nariman Point,
Mumbai 400 021; Tel. No.: 91-22-2283 3458 / 2283 3453 / 2283 3457;



Why can't an audit be accountable?

A philosophy that saves 35,000 tonnes of wood fuel in Tirupur every year.

Forbes Marshall understands the need to conserve forests and reduce our carbon footprints through efficient fuel consumption. That's why, a Forbes Marshall audit report delivers a composite package to optimise fuel consumption. Our team has not only set benchmarks in environmental conservation, but has also helped the textile industry save several hundred crores of rupees on fuel.

Today, Forbes Marshall is the country's leading firm in energy conservation, steam generation and control instrumentation.

We constantly strive to provide better solutions through technology tie-ups and focused investments in manufacturing and research, which give us a distinct advantage over our competitors. Our joint ventures with the world's leading names enable us to deliver world-class products that ensure efficient energy consumption today, for a greener tomorrow.

To find out what we can do for you, please email us at why@forbesmarshall.com

[Energy Conservation](#) | [Environment](#) | [Process Efficiency](#)

www.forbesmarshall.com

P.B # 29, Mumbai Pune Road, Kasarwadi, Pune 411 034, India. Tel.: +91 20 27145595, 39858555, Fax.: +91 20 27147413
A-34/35, M.I.D.C., 'H' Block, Pimpri, Pune 411 018, India. Tel.: +91 20 27442020, 39851100, Fax.: +91 20 27442040

Forbes Marshall | Forbes Marshall Arca | Forbes Marshall Codel | J N Marshall | Krohne Marshall | Spirax Marshall | Forbes Vyncke

Benchmarking Global Standards in

Air Technology

Miracles with Air



AUTOMATIC WASTE EVACUATION SYSTEM

(Energy consumption 35% less compared with leading brands)

HUMIDIFICATION PLANT

(Energy consumption 30% less compared with leading brands)



Manufactured by:

AIR MAASTER INDUSTRIAL TECHNOLOGIES

#64/4, Swarnambika Layout, Ramnagar, Coimbatore - 641 009.
Phone : 91 - 422 - 2230802, 2230297, Telefax : 91 - 422 - 2231183
Mobile : 94440 21682, 94440 06426
E-mail : airmaaster@airmaaster.com



Marketed by:

VOLTAS LIMITED

#1413, Trichy Road, Coimbatore - 641 018.
E-mail : tmdshqcbe@voltas.com
Web : www.voltas.com
A **TATA** Enterprise

Set the Benchmark in Polyester Staple Fiber Production



ITMA 2011

Barcelona, Spain
September 22-29
Hall 2, Booth D131

300 Tons per day Staple Fiber Plants

To capture growth in the polyester staple fiber market producers need a long term competitive edge. A high capacity line up to 300 tons per day from Oerlikon Neumag will decrease your operating cost. With more than 50 years of experience and over 25 installed 200 tons per day staple fiber lines Oerlikon Neumag is your reliable partner.

More information: www.neumag.oerlikontextile.com
Or write to: neumag.staple@oerlikon.com

oerlikon
neumag

67th All India Textile Conference

"Conference With A Difference"



Conference Theme Textile & Clothing- Emerging Global Scenario

4th & 5th February, 2012
at Habitat World, India Habitat Center,
Lodhi Road New Delhi

Branding
Opportunities
Available Through
Conference
Partnership Plans

Contact For

Delegate
Registrations
Open

Advertisements
in Conference
Souvenir

Host : **The Textile Association (India)-Delhi**

For more information or queries, please contact
Conference Chairman: **Ashok Juneja**, +91 989 159 3332 or Conference Secretary: **R. Dudeja**, +91 981 173 0846
Email: 67aitc@tai-delhi.org Web : www.tai-delhi.org



The latest range of products
for the discerning customer.



**Veejay Lakshmi
Engineering Works Ltd.**



**RANDOM ASSEMBLY WINDER &
RE-WINDER**

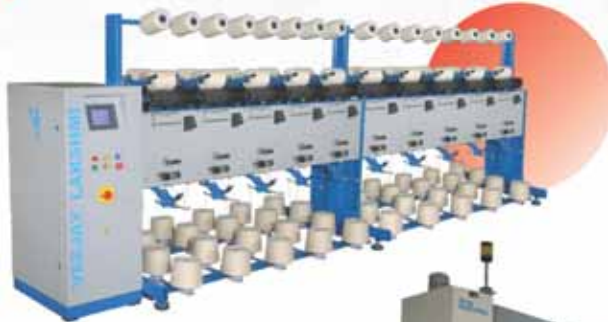

**PRECISION PROPELLER
ASSEMBLY WINDER**



**EXCELLO
AUTOMATIC CONE WINDER**



TWO-FOR-ONE TWISTER



TFO FOR SPECIAL APPLICATIONS

Veejay Lakshmi Engineering Works Ltd.,

Sengalipalayam, N.G.G.O Colony (Post), Coimbatore 641 022, India.
Ph : 91-422 2460 662, 2460 365, 2461 369. Extn. 403 / 404. Fax: 91-422 2460453, 2461565
E-mail: sales@veejaylakshmi.com; spares@veejaylakshmi.com
www.veejaylakshmi.com

Selling Agent: Veejay Sales and Services Limited, Coimbatore.
Branch Offices: Mumbai, New Delhi, Chandigarh, Ahmedabad and Kolhapur.



India's Most Prestigious and Largest Textile Machinery Show



ISO : 9001 : 2008 CERTIFIED

INDIA ITME 2012

9th India International Textile Machinery Exhibition

2nd-7th December 2012

Venue

Bombay Convention & Exhibition Centre,
Goregaon, Mumbai, INDIA

Website: <http://www.india-itme.com>

2 New Chapters Introduced
in INDIA ITME-2012
Garment Machinery,
Chemical Products &
Dyestuff



India ITME Society

Tel : +91-22-2202 0032 /+91-22-2282 8138
+91-22-2285 1579, Fax : +91-22-2285 1578
itme@india-itme.com

ISO : 9001 : 2008 CERTIFIED



The Comfort of Competence

Settle back and relax – thanks to Rieter

Feel at ease and indulge in the comfort of truly tailored support. Our proficient personnel are at your service – from the very first meeting seamlessly through to operations of your spinning mill plant. Rest assured – Rieter provides all four spinning system technologies and will advise you with competence on the best investment in terms of economy and market impact. Benefit from our expert services and enjoy the comfort of partnership with Rieter.

Committed To Quality

International Recognized
Testing Equipment

SDL Atlas — Textile Testing Solution

Colorfastness Testing Instrument & Measurement



Launder Ometer



Crockmeter/Rubbing
Fastness Tester



Perspiration Tester



Color Viewing Booth

Physical Testing Instrument



Digital Elmendorf
Tearing Tester



Martindale Abrasion
and Pilling Tester



ICI/M&S Pilling
and Snagging Tester



Random Tumble
Pilling Tester



PnuBurst
Pneumatic Bursting Tester



Tinius Olsen
Universal Materials
Tensile Tester



Fabric Yield
Package System

Shrinkage Testing



Top-loading
Home Laundry
Washing Machine



Front-loading
Home Laundry
Tumble Dryer



Wascator FOM
71 CLS LAB
Washer-Extractor



Precision
Tumble Dryer



QuickWash Fabric
Testing Systems



AutoFlamm Tester



AFC 45° Automatic
Flammability Tester



Vertical Flame Chamber

Flammability Tester

Advanced Textile Testing Instrument



Sweating
Guarded Hotplate



Hydrostatic Head Tester



Air Permeability Tester



Moisture
Management Tester



Universal Wear Tester

Consumables

For Fastness Testing Instrument & Measurement

Reference Detergent
without optical brightener

Pre-Cut Crocking Cloths
Multifiber

Stainless Steel Ball/Discs

Bleached Cotton
Standard Blue Wool

Grey Scale (Color Change)
Grey Scale (Color Staining)

For Physical Testing

Felt Discs

Blade

Abradent Fabric SM25

Woven fabric

Foam pads

Cork liner

Cotton Sliver

For Shrinkage Testing

Reference Detergent
with optical brightener

Shrinkage Scale

Makeweights

Water proof marking pen



We provide various kinds of other international certificated testing equipment, consumables and standard light source.

SDL Atlas, Ltd
PO Box 162, Crown Royal, Shawcross St.,
Stockport SK1 3JW, England
Tel: +44 (0) 161 480 8485 Fax: +44 (0) 161 480 8580
Internet: <http://www.sdlatlas.com>

SDL Atlas, LLC
3934 Airway Drive, Rock Hill, SC 29732, USA
Tel: +1 (803) 329-2110 Fax: +1 (803) 329-2133
Internet: <http://www.sdlatlas.com>

Premier Colorsan Instruments Pvt. Ltd.,
Exclusive Agent for India
Tel: +91 22 2763 7900 Fax: +91 22 2762 2022
Email: premiercipl@mtnl.net.in
Internet: www.premiercolorscan.com



HIP. ULTRA-HIP!

Constantly changing fashion statements lead to variegated demands of finishing of garments and jeans. In addition to the classical Denim look, our DENIMCOL trademarks also enable the realisation of all fancy demands of changing fashion in this field in a perfect way.

The new GARMENT, JEANS and SPECIAL EFFECTS FINISHING PROGRAMME of CHT offers you an extensive range of fashionable solutions, extraordinary ideas, together with technical know-how.

UNIQUE IDEAS. UNIQUE SOLUTIONS

CHT (INDIA) PVT.LTD. | 121/122 Solitaire Corporate Park | 151 M. V. Road | Chakala | Andheri (East) | Mumbai - 400 093 | INDIA
Tel.: +91-22-61538383 | Fax: +91-22-61538313 | www.chtindia.com



Visit the
**World's Biggest
 Textile & Garment
 Technology Event**



22nd - 29th September 2011
 Fira de Barcelona Gran Via
 Barcelona, Spain

Power your business with ITMA 2011

➤ Discover innovative and cost-effective solutions ➤ Source the latest products and technologies ➤ See live machinery demonstrations ➤ Experience Barcelona's rich art and cultural heritage

An integrated, complete textile and garment technology showcase featuring

- Around 1,400 industry-leading manufacturers from over 40 countries
- New-to-market machinery and products spread over 100,000sqm net of exhibiting space
- Expanded focus on garment making and new fibre and yarn product sector

Abundant industry expertise sharing and networking opportunities

- ITMA Research & Education Pavilion
- World Textile Summit with keynote address by Kofi Annan
- Advanced Textiles 2011 forum by Industrial Fabrics Association International

Be among the leaders at ITMA 2011 - where the world's top textile and garment industry players converge. Visit www.itma.com to sign up your participation and for the updated exhibitor list!

*Get a free
 Barcelona transport
 pass when you order
 your badge online
 by
 15 August 2011*

Show Owner



CEMATEX
 T: +44 7967 477305
 E: info@cematex.com
 W: www.cematex.com

CEMATEX Associations

ACIMIT (Italy)
 AMEC AMTEX (Spain)
 BTMA (United Kingdom)
 GTM (Netherlands)
 SWISSMEM (Switzerland)

SYMATEX (Belgium)
 TMAS (Sweden)
 UCMTF (France)
 VDMA (Germany)

Organiser



MP International Pte Ltd
 T: +65 6297 2822
 F: +65 6392 2905
 E: info@itma.com
 W: www.itma.com

Official Travel Agent

Barcelona Business Pass
 T: +34 93 550 03 55
 F: +34 93 414 17 86
 E: itma2011@beinbeyond.com

Official Airline Network

STAR ALLIANCE
 W: www.staralliance.com

your partner for world class spinning technologies

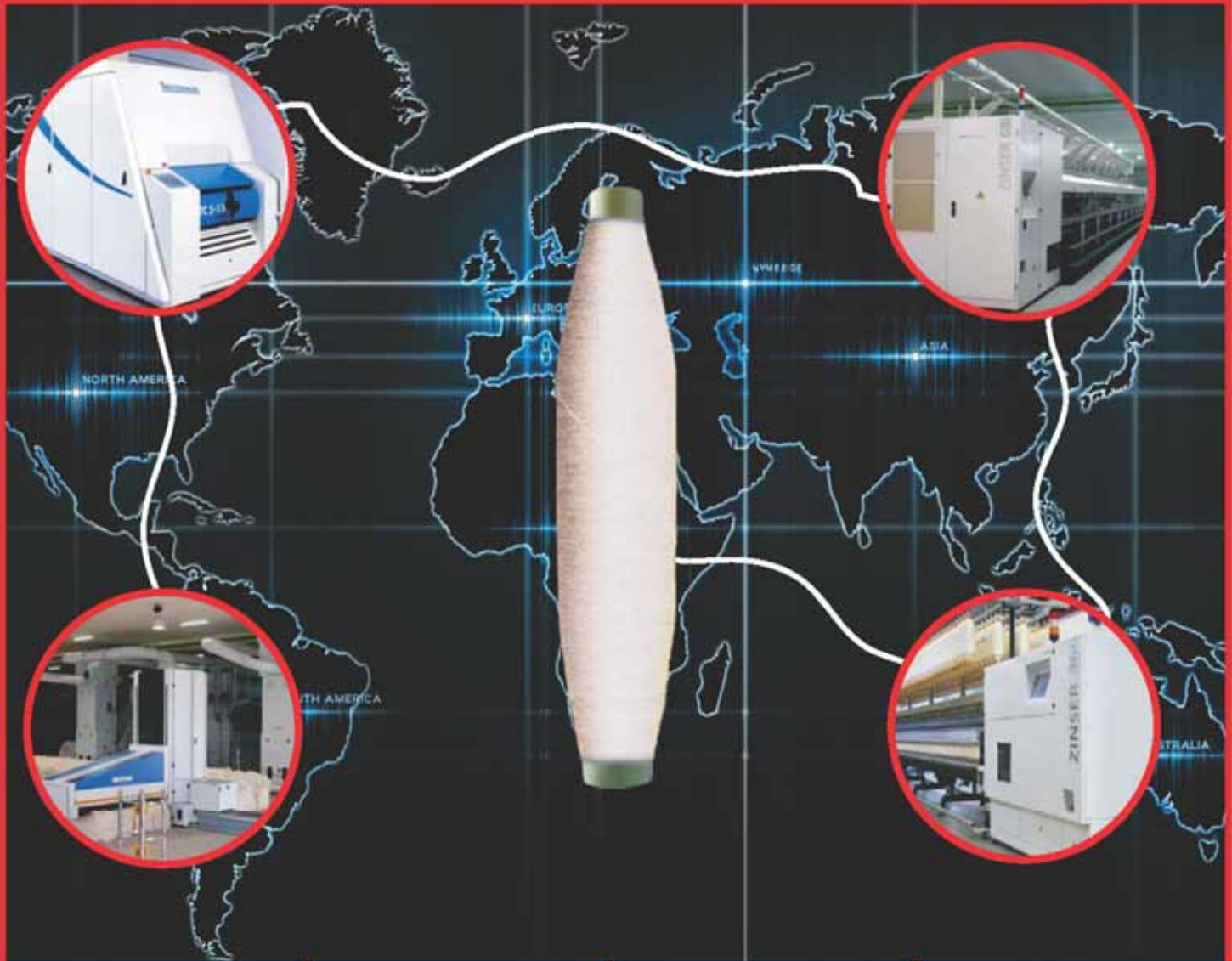

TRUETZSCHLER INDIA

The best blow room,
card & draw frames
manufacturer in India

TRÜTZSCHLER

World leader from
bale to sliver

OERLIKON SCHLAFHORST (ZINSER)

World leader in
spinning technology

OERLIKON SAURER (VOLKMANN)

Innovator in twisting
technology



A.T.E. Enterprises Private Limited

Bhagwati House, A-19, CTS No.689, Veera Desai Road, Andheri West, Mumbai - 400 053 India
T: +91-22-6676 6100 F: +91-22-2673 2463 E: teg@ateindia.com W: www.ateindia.com, www.ategroup.com



AHMEDABAD
T: +91 79 2560 0995

BENGALURU
T: +91 80 2551 0030

CHANDIGARH
T: +91 172 269 7179

COIMBATORE
T: +91 422 222 3286

HYDERABAD
T: +91 40 2789 8132

KOLKATA
T: +91 33 24869811

NEW DELHI
T: +91 11 4555 5000

An ISO 9001-2008 certified company

Join the Orbitz delagation to ITMA Barcelona

Orbitz led the largest delegation to ITMA Munich 2007



Enjoy a luxurious stay
in the heart of Barcelona City

Hotel Diagonal Zero



ITMA 2011
22 - 29 September
Barcelona, SPAIN

Highlights of your stay

- Spacious room – 32 sqm
- Just 15 minutes drive to the exhibition ground
- 3 minutes walk to the Metro Train Station
- Beach at walking distance
- Diagonal Mar Shopping Mall at walking distance (20 mtrs)
- Indian dinners cooked & served by Orbitz's Indian chef in the comfort of the hotel
- Service of Orbitz's experienced Tour Directors
- Meet the industry leaders at the most awaited **INDUSTRY NETWORKING NIGHT**

Over 100 companies
have already
booked with ORBITZ

Orbitz
Business Tours

A Joint Venture with Star Group of Companies
www.orbit-star.com

Book Online : www.visittradefairs.com

For further details, please contact

Orbitz Corporate & Leisure Travels(I) Pvt. Ltd.:101, Navyug Industrial Estate, T.J. Rd. Sewri (W),
Mumbai- 400 015 • Tel.: 022- 2410 2801 - 4, 39504400 • Fax: 022- 2410 2805

Contact Person : Chintan Chheda. Email: btmktg@orbit-star.com

Orbitz Offices: Mumbai • Delhi • Kolkata • Bengaluru • Chennai • Kanpur • Hyderabad • Pune
• Ahmedabad • Coimbatore • Ludhiana • Vadodara • Surat • Nashik • Indore • Cochin

Orbitz Network: Nagpur • Ranchi • Aurangabad • Rajkot • Lucknow • Kolhapur • Jalandhar
• Vapi/Valsad • Raipur • Manipal • Bhopal

Kindly attach your Business Card

Orbitz Corporate & Leisure Travels(I) Pvt. Ltd.:101, Navyug

Industrial Estate, T.J. Rd. Sewri (W), Mumbai- 400 015

• Tel.: 022-2410 2801- 4, 39504400 • Fax: 022- 2410 2805

I am interested in ITMA Barcelona 2011

Kindly send me your brochure

Response Form
JTA

“ We believe in the power of possibilities and innovation for creating unique yet simple solutions for textile processes “

Eco sustainable products
conforming to OekoTEX
GOTS and REACH requirements.



ASPIRE CHEMICALS PVT LTD.,

141, KUBER, NEW LINK ROAD,
ANDHERI(W), MUMBAI - 400053 INDIA
PHONE : +91-22-26730272
TELEFAX: +91-22-26730940

E-mail: glxindia@vsnl.com, info@glxindia.com
WEBSITE: www.glxindia.com



中国国际纺织机械展览会 暨ITMA亚洲展览会 ITMA ASIA + CITME 2012

Shanghai New International Expo Centre, Shanghai, China

12-16 June 2012

Asia's Leading-edge Business Platform

www.itmaasia.com | www.citme.com.cn

Apply for exhibition space today. Deadline for applications

15 October 2011

Be part of Asia's most prestigious textile machinery industry event that features

- Stringent enforcement of intellectual property rights
- A mega showcase of cutting-edge solutions for textile makers
- Strong support from key major textile machinery trade associations around the world
- Exhibits presented by product category for the convenience of visitors
- Over 1,000 exhibitors, 100,000 trade visitorship, and 120,000 square metres of exhibition space

Owners



Organiser



Co-Organiser



In Partnership with



For more information, please contact

CEMATEX

PO Box 248, Newcastle upon Tyne, NE7 7WY, United Kingdom

Tel: +44 7967 477305

Email: info@cematex.com

Beijing Textile Machinery International Exhibition Co. Ltd

No.12 East Chang An Street, 100742, Beijing, China

Tel: +86 10 8522 9662 / 8522 9372 / 8522 9406

Fax: +86 10 8522 9480 / 8522 9026

Email: itmaasiacitme2@bjitme.com

A TOUCH OF DORNIER



“Quality creates value” – when it comes down to safety and comfort, technical textiles woven on DORNIER weaving machines are a class of its own. Whether bullet-proof aramide, glass or carbon, whether finest light-weight spinnaker cloth, airbags or breathable high performance fibers: The DORNIER weaving machines produce the best possible cloth quality at the most reasonable cost in all these areas.

The DORNIER system family of air-jet and rapier weaving machines has served as a reliable tool for pioneers and market leaders for decades. Now the new generation of A1 and P1 weaving machines sets the top level of weaving another notch higher.

Quality creates value

DORNIER

WEAVING

www.lindauerdornier.com



VI SWAAT

www.viswaat.com

An ISO 9001:2008 Certified Company



WEAVING SOLUTIONS FOR UNSIZED YARNS **VISCOL AW-52**

Viswaat Chemicals Ltd. an ISO 9001 : 2008 certified company is a leading manufacturer of Speciality chemicals for various industries like Textile, Pharma, Leather, Agro, Fibre Glass, Construction, Paper, Refinery etc.

Viswaat with its customer centric approach and constant R&D brings a gamut of products from Fibre finishes to Fabric finish for the Textile industry.

Our innovative products give you unmatched advantages like consistent quality, cost economics and superior technology. Our Range of Products for Textile Sizing include **Acrylic Sizing agents, Sizing Softeners, Antistatic agents, Lubricants & Afterwaxing agents.**

PRODUCT FEATURES :

- *Ecofriendly, Biodegradable & APEO/NPEO free*
- *Ready to use Product at Room temp*
- *Reduces fibre to fibre friction due to superior lubricating Properties*
- *Gives excellent binding Properties & hence less end breaks & increased weaving efficiency*
- *Excellent Antistatic property*
- *Imparts smooth feel to the Woven fabrics*
- *Improves appearance of Woven Fabric due to less mending*
- *Improves good Packing percentage*
- *Is easily removed by washing in cold water*



**Oekotex-100
GOTS
REACH**

Viswaat Chemicals Ltd.

7 Satsang Complex, Upper Govind Nagar, L. S. Rajha Marg, Malad (East), Mumbai - 400 097, India.

Tel : +91-22-2874 0365, 3245 2211, 3240 9612 • Fax : +91-22- 2874 5321

Email : info@viswaatchem.com, textile@viswaatchem.com



Chalo Barcelona

Let us go for the Olympics of textile engineering, ITMA 2011, to Barcelona, Spain, the land of football, bullfights, and Picasso's inspiration. Textile engineering teams from across the world will be converging there to demonstrate their prowess and technological feats. The world's most favoured Indian brand of aprons and cots PRECITEX will be there, to welcome you warmly with its great range of products, developed and designed to enhance your productivity, quality and cost effectiveness.

**MEET PRECITEX AT
HALL NO. 2, STAND C165**



PRECITEX
World Class Aprons & Cots

PRECISION RUBBER INDUSTRIES PVT. LTD.
(An ISO 9001:2008 Company)
201 A, Poonam Chambers, Worli, MUMBAI 400 018.
Tel: +91 22 40766444 / 40049750 Fax: +91 22 66605382 / 66605383
E-mail: sales@precitex.com Web Site: www.precitex.com



ITMA 2011
www.itma.com
22-29 September
Fira de Barcelona
Barcelona, Spain

Bekaert Carding Solutions at your service...

A wide range of carding wires with excellent performance



Short staple carding solutions

@ BEKAERT

better together

The reliable partner...

Looking for the best carding solution for your short staple application? Bekaert might be just the reliable partner you are looking for.

Through partnerships with textile machine builders and customers world wide Bekaert strives to be the independent and recognized leader in the card clothing business.

By enabling our customers to benefit from our know-how, technological strengths and operational excellence, we believe that we can deliver you carding solutions that are truly unique.

The Bekaert group is a European based company, headquartered in Belgium and generates annual combined sales of € 4.5 billion. The 27 000 employees around the world work together as one company, serving customers in 120 countries.

www.bekaert.com

Visit us at :
Hall No. 2
Booth C125-126



ITMA 2011
www.itma.com
22-29 September
Fira de Barcelona
Barcelona, Spain



The Textile Association (India)
(Founded 1939)

EDITORIAL BOARD

Chairman : Prof. (Dr.) M. D. TELI
*Institute of Chemical Technology,
University of Mumbai*

Editor : Prof. (Dr.) R. V. ADIVAREKAR
*Institute of Chemical Technology,
University of Mumbai*

MEMBERS

Dr. ARINDAM BASU (*SITRA, Coimbatore*)

Mr. C. BOSE (*Bose & Co., Mumbai*)

Dr. A. N. DESAI (*BTRA, Mumbai*)

Prof. C. D. KANE
(*D.K.T.E.'s Textile & Engg. Institute, Ichalkaranji*)

Mr. A. K. PRASAD (*Clariant, Mumbai*)

Dr. AJAY SARKAR (*Colorado University, USA*)

Dr. H. V. SREENIVASAMURTHY
(*Advisor, NMIMS-CTF, Shirpur*)

Mr. K. L. VIDURASHWATHA
(*Technical Advisor, Rossari Biotech, Mumbai*)

Publisher : J. B. SOMA

OFFICE BEARERS

President
Mr. D. R. MEHTA

President Emeritus
Dr. P. R. ROY

Vice-President
Mr. ASHOK JUNEJA

Chairman
Mr. K. D. SANGHVI

Vice-Chairman
Mr. T. L. VISWANATHAN

Hon.Gen.Secretary
Mr. V. D. ZOPE

Hon.Jt.Gen.Secretaries
Mr. HARESH B. PAREKH
Dr. N. N. MAHAPATRA

Hon.Treasurer
Mr. V. N. PATIL

Chairman - J.T.A. Editorial Board
Prof. (Dr.) M. D. TELI

Chairman P. A. C.
Dr. H. V. SREENIVASAMURTHY

Chairman B. P. C.
Prof. ASHWIN I. THAKKAR

© THE TEXTILE ASSOCIATION (INDIA)
Published by PAVITRA PUBLISHER
7A/203, New Dindoshi Giridarshan CHS.,
Near N.N.P. No. 1 & 2, New Dindoshi,
Goregaon (E), Mumbai - 400 065
M. : 9819801922
E-mail : somajb@yahoo.co.in

ISSN 0368-4636

May-June 2011 - Volume 72 No. 1



Journal of the TEXTILE Association

TEXTILE SCIENCE ■ TECHNOLOGY ■ ENGINEERING ■ MANAGEMENT

CONTENTS

| | |
|--|-----------|
| Editorial | 2 |
| R. V. Adivarekar | |
| A Review of Different Measures to Eliminate Contamination from Cotton | 5 |
| Suchibrata Ray, Biswapati Chatterjee | |
| Warp Knitted Structures for Technical Use | 9 |
| Palash Paul, Debiprasad Gon | |
| E-control-The Ecofriendly Process | 23 |
| Ajinkya Khot, Chandrakant Lende | |
| Compression Bandage Coated with Micro Encapsules of Herb Ziziphus Jujuba Extract | 27 |
| A. Shanmugavasan, T. Ramachandran | |
| Shopping Behaviour of Teen Age Girls in Mumbai City | 32 |
| A. J. Shukla | |
| Texspecial | |
| Significance of Corporate Social Responsibility in the Trade of Retail Branded Apparels | 36 |
| Shraddha M. Teli | |
| Texperience | |
| Textiles volumes are shifting South-East Asia | 42 |
| Arvind Sinha | |
| Texnotes | |
| Carbon Footprint in Textiles | 44 |
| Chet Ram Meena | |
| OTHER FEATURES | |
| WTC Review | 47 |
| Unit Activities | 61 |
| News | 65 |
| Advertisement Index | 72 |
| Product Technology | 73 |
| Forthcoming Events | 74 |

JTA is Abstracted by :

| | |
|---------------------------|-------|
| Chemical Abstracts, | USA |
| World Textile Abstracts, | UK |
| Indian Science Abstracts, | India |
| Texincon, | India |

JTA is a Bimonthly Publication of

THE TEXTILE ASSOCIATION (INDIA)

Pathare House, R. No. 6, 2nd Floor, Next to State Bank of India,
67, Ranade Road, Dadar (W), Mumbai - 400 028.

Phone: (91-22) 2446 1145 Fax: (91-22) 2447 4971

E-mail: taicnt@mtnl.net.in

www.textileassociationindia.org

Printed at SUNDARAM ART PRINTING PRESS

12, Wadala Udyog Bhavan, Naigaum X Road, Wadala, Mumbai - 400 031. Tel. : 022-2412 6942

Editorial

Textile World: Full of Dynamism and Optimism

*W*orld Textile Conference was very successfully organized by the Textile Association (India) central office along with Institute of Chemical Technology (formerly UDCT) as Institute Partner and it was supported by the Office of Textile Commissioner. Over 600 participants attended this conference where more than 30 presentations were made and panel discussions were also held on some of the important issues relating kind of opportunities the coming decade will bring in for Indian Textile Industry and the types of strategies which are required to be adopted to reap the maximum fruits of such opportunities.

It was indeed a highly successful two day Conference which sent optimism among the Textile fraternity and everyone agreed on the point that the demand for Textiles and Apparels will certainly increase, while margins may come under pressure because of raw material and utility costs as well as rising interest rates. Discussion about the success stories of some of the Brands and Chinese business model generated lot of interest. Everyone agreed that the young population in India and China will further fuel the demand, and it will be a great challenge to China to meet the International demand while having an obligation to look after their domestic needs. This will cause an unmet spill over in Chinese export share in the International trade and even 10 % of such share will certainly bring in drastic increase in demand for Indian goods.

Another segment which clearly came out as dominating one with high potential for growth was Technical Textiles and two of the sessions in the conference deliberated on it. The Government of India's Textile Ministry is also setting up 8 Centres of Excellence in various segments of Technical Textiles, which further indicates the scope for the growth in this sector. The recent news that the Government is thinking of allowing 100% FDI in this segment is also an indication of the need to make this segment well rooted in the Country and it is hoped by the Government that by 2012, about Rs. 5000 Crore worth of FDI will come in the Technical Textiles.

Another step of the Government taken to boost the training activities of the workers in order to meet the needs of the Industry is also acquiring fruits. Recently the Textile Ministry had launched an Integrated Skill Development Scheme for Textile and Apparel sector including jute and Handicrafts. This was essential as the exporters were finding shortage of skilled manpower and they were looking for consultants to train such manpower. Ministry of Textiles has selected Textile Committee as a statutory body under it as one of the implementing agencies to create a pool of

Quality Assurance Professionals in various Textile and Apparel Fields and the first of its Training Programme was inaugurated by the Secretary Textiles, Mrs.Rita Menon, on 20th June 2011. The Textile Committee is going to train more than 4500 professionals in various fields. This is very important when we see the opportunities for this sector increased and the production levels commensurately would have to be also increased by a number of times. While this happens, at no juncture internationally accepted quality standards can be compromised and it is here Quality Assurance Professionals will act as the key catalyst in the whole process. This cannot be possible unless trained manpower is made available and hence it is one another step forward by the Ministry to boost the training activities. We congratulate Textile Committee staff and Member Secretary Mr. Balamurugan for coming forward to shoulder this important responsibility in the national interest.

Third and major development taking place on the Horizon of Indian Textile Industry is Institute of Chemical Technology, which is formerly called UDCT, has signed a MOU with a number of leading Industries such as DyStar and recently with BTRA. Very soon Textile Committee and WRA will also sign such MOUs with ICT which will give further impetus for the joint research work and guiding of students for M.Tech and Ph.D.s. While we are proud to have Prof. Yadav (Vice Chancellor) and Prof. Teli (Dean- SAHRD) with us at the ICT who initiated such step and Prof. Teli was aptly awarded by the Textile Association India by its first ever award of Academic Excellence recognising his contribution to Education, Research, Industry as well as various Associations and Government Bodies. We are sure with such a synergy, all the institutions involved will build on their strengths and Industry as well as all the stake holders including students will definitely benefit out of it and hence we all must support such initiatives.

Coming back to the World Textile Conference about which a detail report is presented in this issue, while majority of the participants admired the efforts of the organizers of this conference, it is sad that one of the publications for the agenda well-known to them only, took a negative stand and published where the Organizers defaulted according to their understanding. Sadly most of the issues concerned with docket, gifts and physical arrangements. Most importantly it did not report on quality of presentation, planning and time management on the stage as well as fully packed enriched package of information on varied topics through selected speakers of high repute. Which conference did they see 80 to 90 % participants present till last session of the Conference? They did not talk about it at all, infact making others to believe, that for them, only other things did matter. When such reports are read by those who attended the Conference, how badly the reputation of such publication suffers is only any body's guess. This does not mean there were no hitches, but you have the way to put it if your intention is to suggest improvement. I only hope next time while reporting, they will take a more balanced stand so that at least their credentials will not be suspected.

Prof. Ravindra Adivarekar
Editor, JTA

Journal of the
TEXTILE ASSOCIATION



THE TEXTILE ASSOCIATION (INDIA)

Pathare House, R. No. 6, 2nd Floor,
Next to State Bank of India, 67, Ranade Road,
Dadar (W), Mumbai - 400 028.
Phone: (91-22) 2446 1145
Fax: (91-22) 2447 4971
E-mail: taicnt@mtnl.net.in, somajb@yahoo.co.in
www.textileassociationindia.org

Subscription Form

Dear Sir,

I would like to subscribe to **Journal of the TEXTILE ASSOCIATION**

Name : _____ Designation : _____

Organization Name: _____

Address (Office) : _____

City: _____ Pin: _____ State: _____ Country: _____

Phone: _____ Fax: _____ E-Mail: _____

Mobile: _____ Area _____

Payment enclosed:

Cheque / DD No.: _____ Dated _____ For Rs. _____

Drawn on : _____ Favoring **The Textile Association (India)**

Please attach your visiting card

| Tick | Term | No. of Issues | Price |
|--------------------------|---------|---------------|----------|
| <input type="checkbox"/> | 1 Year | 6 | ₹.500/- |
| <input type="checkbox"/> | 2 Years | 12 | ₹.900/- |
| <input type="checkbox"/> | 3 Year | 18 | ₹.1300/- |

Please add Rs. 50/- for outstation cheques

(Stamp & Signature)

A Review of Different Measures to Eliminate Contamination from Cotton

Suchibrata Ray*, Biswapati Chatterjee

Government College of Engineering and Textile technology

Abstract

Today the quality control is practiced right from the initial stage of cultivating cotton fibre to the stage of finished product. Increased awareness and quality sensitivity of the present day consumer has demanded more contaminated free product. Among all other important quality parameters of cotton product, contamination remains one of the burning issues at present. Here, we have tried to highlight the sources and remedial measures for contamination, practiced in the cotton cultivation to yarn manufacturing industry.

Keywords

Contamination, Cotton fiber, Efficiency, Hand sorting, Polypropylene.

1. Introduction

Contamination remains a burning issue in the field of textile. Increased awareness among the users has made it more acute. Continuous change in human taste and phenomenal up/gradation in the area of fashion has imposed a real challenge to the Textile Industry. Moreover, the presence of contamination in the final product results into degradation of quality. Therefore contamination issue was a threat for the industry throughout the last decade and it is prevailing at present as well. On analysis it was found that among all the areas of textile sectors, "Fibre cultivation to Yarn spinning stage" remains major source of contamination. Therefore we have highlighted certain facts and few recent developmental steps, which are being taken to reduce or minimize the contamination level in this area.

2. Nature of Contamination

Before finding any measures for elimination of contamination we must focus and understand the probable sources of contamination. Once the sources are sorted out, elimination process becomes effective and easier. Contamination is broadly defined as any sort of unwanted foreign material added in different processing stages starting from cultivation to final yarn preparation [1]. In real case, yarn manufacturers are

more worried about input contamination in raw material i.e. cotton bales [1]. Contaminations are not being grown with cotton balls in the tree. As these are mostly "added" in fresh cotton, therefore measures must be taken to prevent the addition as a very essential and important measure.

Definitely any possible measures to eliminate the contamination involve certain cost, which indirectly causes the value loss in final product. But on other hand, value loss because of presence of contamination in final product is much higher than value loss due to cost involved in the contamination elimination processes. Therefore, it is an important area to be focused.

Also we must be aware about the type of contaminations, which are generally available in cotton bates. The nature of contaminants is as under in order of its increasing importance / seriousness:

- (i) Polypropylene (White Et Coloured)
- (ii) Hair
- (iii) Coloured threads
- (iv) Cloths
- (v) Plastics
- (vi) Jutes
- (vii) Woods
- (viii) Iron pieces
- (ix) Others (paper, bir & feather, shoes, match box, etc.)

*Correspondance should be addressed to,

Suchibrata Ray
Government College of Engineering and Textile Technology, Serampore
12, William Carey Road,
Serampore-712201, Hooghly, West Bengal
E-mail: raysuchi@yahoo.co.in

3. Contamination at different stages of cotton processing

The cotton cultivation to bale formation is prone to introduce large number of contaminations[1].

3.1 Addition of contamination at raw cotton stage takes place because of following reasons

- by human being, involved in picking of cotton, ginning, sorting & packing processes
- by machines, involved in ginning transporting and packaging
- from different accessories like bag [2] used for carrying, wooden baskets used for picking, etc.
- because of improper location/field selected for ginning, storing and packing. If storing and packaging is done at open-air area, a heavy blow of air/storm can add many unwanted foreign materials from the outside area /atmosphere.

3.2 There are few possibilities of adding certain type of contaminations during processing, starting from mixing to final yarn spinning (ring frame). These are as follows

- by human being, involved in mixing lay down preparation, contamination sorting processes at blow room stage, material handling, material transportation and machine operation at every stages of yarn manufacturing from carding to ring frame.
- by human being, involved in maintenance of all the machineries. During maintenance work, chance of addition of grease/oil/dirty fly is always there.

4. Different measures taken to eliminate contamination

Few modern methods have been adapted as well as electronic systems have been developed to remove added contamination from the cotton throughout the yarn manufacturing process. These developments definitely have helped the spinner to remove the contamination with certain amount of efficiency but controlling of added contamination in different stages is the only way to eliminate contamination indirectly. Modern approaches and electronic systems, which are now incorporated in the manufacturing processes, are described below:

4.1 Cultivati on to Bale formation

4.1.1. Electronic Contamination control system

Today in many ginning factories, electronic contamination control systems like vision shield of

Rieter, Contamination Controlled System have been installed in the transportation line between ginning and storing) before putting the cotton fibre into Bate press. Here in this stage, cotton tufts are in open form and CCD camera installed in the equipments detects the contaminants (foreign matter) with different colour other than cotton and enable ejection simultaneously from the flow along with some amount of good cotton.

Normally this system does not work for white coloured contaminants like small pieces of white polypropylene sheets or strips. This system is effective for hair, dyed yarn, coloured fabric, jute. The average efficiency of this contamination control system is around 40-45% at this stage.

4.1.2 Manual method

A skilled group of workers are engaged to take out the contamination from the material. In different stages of ginning, transporting & bate pressing, a group of workers called sorters are engaged to keep a constant watch and take out the contamination from cotton flow, if noticed.

Also, now-a-days ginners prefer to use cotton cloth in place of jute bag for bate packing because there is every possibility of adding jute contamination in the fresh cotton while using jute bag.

4.1.3 Methods/practices for preventing added impurities

- A detailed awareness programme is conducted for the people engaged in the cotton picking, ginning and bate pressing processes. Workers/operators use cap, white coloured scurf their head to prevent the addition of hair contamination.
- Right place is to be selected so that abnormal atmospheric condition like storm or air blow does not influence any addition of unwanted foreign matter in the fresh cotton [1].
- Operators hands to be properly cleaned before starting picking, sorting and packing.
- No worker is allowed with shoes, match box, bidi, chunri, chocolate, ghutka, tambaku in the storing and packaging area.
- Ginning machine, bate press and all other machines are to be checked for any loose parts because it may go with the cotton bate.
- Jute bags/cotton bags with loose/teared ends, broken wooden/bamboo baskets are to be avoided for use.

4.1.4 Improvement in monitoring process

All the above mentioned ways of addition is majorly influenced by the improper supervision. Now-adays there is a trend of improvement after increased involvement of different yarn manufacturing corporate houses. The corporate houses are so concerned with this contamination issue that they have come forward to involve themselves in the cultivation and ginning processes. In many occasion it is found that the corporate houses have adopted many cotton growing villages. They themselves are continuously monitoring the processes step by step directly. It has encouraged the domestic cotton growers and ginners to improve their efficiency in terms of less contamination addition. It is true that involvement of corporate houses has increased the cost factor but the improvement of contamination level in cotton bales results in higher value addition compared to the cost incurred in corporate monitoring and involvement process.

4.2 Mixing Stages to Yarn package formation

Contamination removal process starts at the mixing stage and continues up to winding at autoconer. The different methods normally practiced are briefly described below step by step:

4.2.1 Mixing stage

Hand sorting: 100% material is sorted for contaminants by a skilled work force manually. It may be single sorted or double sorted as per quality requirement.

Sorting efficiency: Sorting efficiency should be a measurement stick to judge the performance of every individual sorter. More stress is given to stretch out this efficiency level. The sorting efficiency expressed in percentage may be defined as:

$$\text{Sorting Efficiency(\%)} = \frac{\text{Number of contaminants removed (Number)} \times 100}{\text{Number of contamination available per Bate} \times \text{sorting Load}}$$

A typical range of sorting efficiency is 55 -70% with a sorting load of 165 kgs/person/8 hours. Here, 65% efficiency means the mixing sorter is able to take out 65 contaminations out of 100 contaminations available in the bate white sorting the bate with standard work load.

4.2.2 Blow Room

4.2.2.1 Sorting under Unifloc during running process
A group of skilled workers are put on the bate group

under unifloc/blendomet and pick up the contaminants from the exposed bate surface. Normally 4-6 operators are engaged under unifloc or btendomet for 32 - 40 bates lay down. In this stage of process comparatively bigger sized contaminations which are visible in open eye are , removed. The nature of contaminations, which are removed by the mixing sorters /operators are any kind of cloths, tong threads, jute cloth and yarns, hairs, wrapper of chocolates, stones, iron pieces, coloured threads, birds feather, thin sheets and strips made out of coLoured polypropylene, ghutka wrappers. Sorting efficiency: 40-45% with sorting load of 500 kgs/sorter/ 8 hours.

4.2.2.2 Ectronic system

The contamination removal systems like Vision shield or Contamination Controlled System are installed in the blow room line after 2 cleaning points so that the exposure of tuft surface is maximized. This instrument locates and ejects the contamination along with some amount of fresh material. Beside the removing of important contaminations, it also removes some dirty cotton which is different in coLour other than fresh white cotton. The working principal of such electronic devices are already discussed in para 4.1.1.

Sorting efficiency of this instrument (individually): 20 -32% with 400 kgs/hour line production.

4.2.3 Carding and Comber

There is no direct contamination removal procedure or system available or practiced. But many contaminants especially plastics, threads and hairs are removed through waste automatically.

In case of carding, contaminants are removed with flat and ticker-in waste. In case of comber most of the hair contamination is removed through noil.

4.2.4 Ring Frame

No direct contamination removal procedure or practice is available. But in the ring frame, yarn breaks where contamination is present in many occasions. These contaminants go into pnumafit wastet, although it does not occur most of the time for very fine fibre shaped plastic contaminations. Very fine fibre shaped plastic contaminations with comparatively longer length than cotton fibre is spun into the yarn.

4.2.5 Winding (Auto Coner)

This is the most important area where everybody gives

attention to remove maximum contaminations from the yarn. The procedures are as described below:

4.2.5.1 By using Electronic contamination channel called FD (foreign matter detection) channel

The electronic clearing device is installed in each head of the autoconer. Such kind of electronic contamination clearing channels are available from different manufacturers like Uster[2], Loepfe, Keissoki, Premiere. The working principle is almost same and optical based for all the manufacturers. During yarn winding this channel measures the colour intensity of the yarn and compares the yarn portion every 2mm continuously against the base white yarn. In case of variation in colour intensity, it detects and actuates the cutter assembly to cut the contamination portion. The intensity/ threshold value can be changed as per requirement and sensitivity of the product quality.

In addition to the basic foreign matter detection channel there are "vegetable filter" available. This vegetable fitter helps to avoid cutting for vegetable matters like leaf, stem, jute inspite of having different colour intensity for those faults than grey yarn. Such types of vegetables need not be removed because these matters are removed during scouring and bleaching process. In the same time, saving of breakage with the help of "vegetable fitter" improves the autoconer's efficiency level.

4.2.5.2 By using PP(Potypropylene) contamination detection channel

Very recently many manufacturers such as Uster, Loepfe, Zenith, Keissoki have developed white PP contamination detecting devices. This device helps to

detect the white cotoured poly → propetene contaminants by using UV light. Under UV light, white cotoured polypropylene contamination becomes detectable. The cutting of detected PP contaminations is sarne as cutting of normal contamination, described in para ~ 4.2.5. 1.

Efficiency of FD channel: It varies with channel setting. At closest level it gives around 70-80% efficiency but the cuts level abruptly increases, which indirectly reduces the machine efficiency to a large extent.

5. Conclusion

Different measures practiced in cotton ginning to yarn manufacturing processes have been reviewed. The involvement of big textile corporate houses in the cotton cultivation and cotton ginning areas has changed the outlook of that industry. More and more involvement will definitely improve the contamination removal efficiency of the industry and as a result such a burning issue of contamination may be solved with ease. Increased awareness among the work force is a key area for preventing addition of contamination. But this area needs importance and attention further. Although a phenomenal. development in the electronically controlled contamination removal system has given the industry an edge but further development is essential to improve its efficiency and sensitivity level.

References

1. www.scribd.com/doc/25209194/Contamination-A-Big-Threat-to-Yam-Quality-in-Spg-Textiles
2. Agarwal K.K., *5th Joint Technological Conference*, NITRA, Gaziabad, 18-25, (2010).



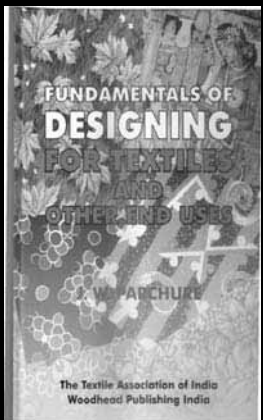

FUNDAMENTALS OF DESIGNING FOR TEXTILE AND OTHER END USES

J.W. Parchure: 2009, Pages 80 * Rs. 495; \$ 35

Very suitable and useful design book for faculty, students of fashion & design beigneers in textile and related design jobs.

Special discounted price offered only Rs. 300/- per copy*

Book your order with The TEXTILE Association (India)
Tel. : 2446 1145, Fax : 022-2447 4971, E-mail : taicnt@mtnl.net.in

Grab you copy, before stocks run out...

Warp Knitted Structures for Technical Use

Palash Paul*, Debiprasad Gon

Department of Textile Technology,
Panipat Institute of Engineering & Technology

Abstract

Textiles are no more limited for use as clothing. Nowadays textiles come to our help in every walk of life directly or indirectly, starting from its use in agriculture sector to very high sensitive medical applications. New end uses are developed daily and in most cases textile structures are used to replace expensive, heavier or technically inferior construction traditionally produced from other materials. Although previously warp knitted structure was exclusively used for the production of garments or decorative parts of the garment manufacturing, but with the advent of new and modified warp knitted structures, these materials are now being used in every sector of technical application. In warp knitted technology every loop in the fabric structure is formed from a separate yarn called warp mainly introduced in the longitudinal fabric direction. The best description of warp knitted fabrics is that they combine the technological, production and commercial advantages of woven and weft knitted fabrics. While weft knitted technology is mostly involved in apparel production, warp knitted technology is substantially engaged in manufacturing structures for technical application. This paper describes the structure and application of the warp knitted structure in production of technical textiles.

Key words

3D Structure, DOS structure, Mesh, Technical Textile.

1. Introduction

Technical textiles are the main constituents of the non-apparel uses of textiles. Most of the technical textiles are comparatively recent additions in textile bandwagon. The production of technical textiles is a rapidly developing trade in the textile industry. Due to availability of high performance fibre and their manufacture into bonded fibre fabrics as well as other engineered fabric with the relevant finishing process, technical textiles have come to the foreground of textile interest. Modern technical textiles are indispensable material and tools for science and technology.

Warp knitting is a method of making a fabric by normal knitting means, in which the loops made from each warps, is formed substantially along the length of the fabric. It is characterized by the fact that each warp thread is fed more or less in line with the direction in which the fabric is produced. Each needle within the knitting width must be fed with at least one separate and individual thread at each course. It is the fastest method of converting yarn into fabric, when compared

with weaving and weft knitting [1].

Warp knitting is by far the most versatile fabric production technology today for producing technical and household textiles. This technology is now used to produce some hi-tech products, which were unimaginable even few decades ago. Warp knitting offers a very wide potential not only for design and for defining the product properties, but also for problem free manufacture of non-textile yarns such as glass fibre yarns, carbon hi-tech textile products.

The flexibility of warp knitting techniques makes them attractive both to the designer, and the manufacturer of technical textiles. There is increased application of warp knitted structures to the technical textiles in recent years. Advantages with respect to the mechanical properties, high productive knitting machines and use of synthetic yarns opened new ventures for warp knitted technical textiles.

2. Warp Knitted Structures for Technical Use

Warp knitted technical textile structures are broadly divided into four categories [2].

1. Basic Construction
2. Three Dimensional Structure
3. Directionally Oriented Structure
4. Composite Fabric

*Correspondance should be addressed to,

Palash Paul,
Department of Textile Technology,
Panipat Institute of Engineering & Technology
Panipat – 132103
E-mail: palashiitd@rediffmail.com

2.1 Basic constructions

Three types of basic construction are mainly used. These are discussed below-

2.1.1 Elastic Structure

An elastic warp knitted structure is produced from polyester yarn with fabric weight of 75 to 300 gsm. The elastic fabric is then deformed into honeycomb shape, impregnated with resin and cured. The product is a light weight, three dimensional and extremely tough honeycomb construction. Placed between two plates it is used to form panels and floor boards where mechanical performance is important.

The sandwiched panels thus produced are light and flame resistant, are pasted. These panels are used for renovating and constructing partition walls and floors in interior construction industry. Another example of its use is the floor board of a yacht; the panels can also be made curved to make heat insulating seats. Cable duct made from curved panels are extremely light and highly stable, and are used for aircraft construction. These panels, made from carbon fibres, are now intended for used for load bearing parts in aircraft, manufactured by the American aircraft manufacturer Boeing. This enabled 25% weight to be saved.

2.1.2 Close Structure

Stable close structures are used to produce high quality fine, soft flags from polyester yarns. Warp knitted flags, as opposed to woven flags, are characterized by better drape, and as a result of more voluminous loop binding by increased movement in the wind, they do not tear, and tear propagation resistance is very high. These types of flags were extensively used in Barcelona Olympics. Washable protective clothing for painters, varnishers, forest workers are made from breathable warp knitted fabric. Perspiration vapour can come out through this type of work wear, but the varnish fumes cannot penetrate from outside.

A close warp knitted fabric made from hollow polyester is given a boil resistance coating for use in hospital. The medical textiles are permeable to vapour of sweat but impermeable to water. This type of fabric is used for protective clothing in operation theatres and as water proof sheet for beds in hospitals.

Fine warp knitted fabric made of polyester are used as sun filters for houses, winter gardens and camp-sites. These fabrics are coated on the outside with aluminum,

by vapour deposition, in order to reflect sun rays and on the inside they are transfer printed with designs. This type of sun filters are also used in cars in the form of roller blind.

2.1.3 Open Structures

A stable open structure made of glass fibre yarns and coated with a special resin is used as a medical textile to replace the traditional plaster cast. This is very simple to apply and has only a fraction of weight. Similar warp knitted net structures made of polyester/cotton yarns applied with gel are used as surgical coverings in medicine. The size of the fabric apertures or the width of inserts is selected freely as suitable surgical coverings are made for every type of injury.

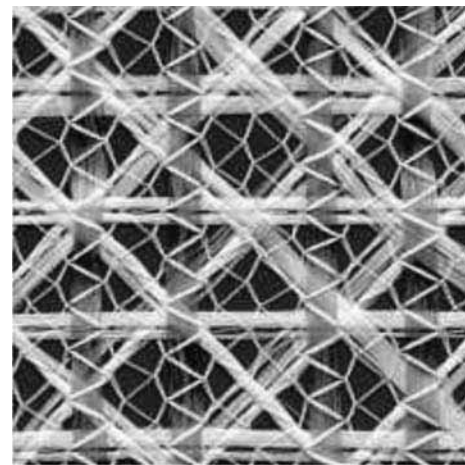

Fig.2.1 Open Structure with +45° / 90° / -45° / 0°

The most popular and effective way of producing open structures in warp knitting are various net structures. The nets are manufactured according to various end uses. Some of the end uses are fishing net, fish trap, catching and breeding aquatic animals nets, protective netting, nets for reinforcing river banks, cliffs, slopes and erosion protection nets, snow fences etc. Nets of extremely fine construction are used as shade nets for car rear windows. Heavy duty nets are used to protect pedestrians and car passing near a construction site. Similar nets are also used behind the goal post in a football ground.

Wide open mesh strips of netting for covering bales of straw and hay are being used in agriculture sector. A typical very light weight pallet wrapping net made from polyethylene film is used to stabilize bales of hay in the field. Similar nets are also used to wrap stacks of crates for safer shipment and to pack together fruit and vegetables trusses into large, stable units for transporting

to the wholesale market.

A high-tech use of warp knitted nets is as reflector mesh in space antenna. A fine warp knitted fabric made of gloss-plated molybdenum wire (30mm dia) with a weight of 79 gsm is used to make the reflector which is 5 meter in diameter when completely unflured. The antenna is folded up for transportation to space by the European carrier system Ariane of the American space shuttle.

The largest use of warp knitted open structure is net curtains. More than 80% net produced today are warp knitted. Raschel warp knitting machines with multi-bars or a fall plate patterning device, or jacquard, or magazine weft insertion system produce most exquisite curtain nets with filament and fancy yarns. Some of these machines are also used to produce table cloth and bed spread with similar fabric constructions using other yarns and patterns.

2.2 Three Dimensional Structure

Unlike flat knitted structure, three dimensional knitted fabrics are manufactured on warp knitted machines with two needle bars. Using these technology two complete different type of products are manufactured, knitted spacer fabric and tubular warp knits.

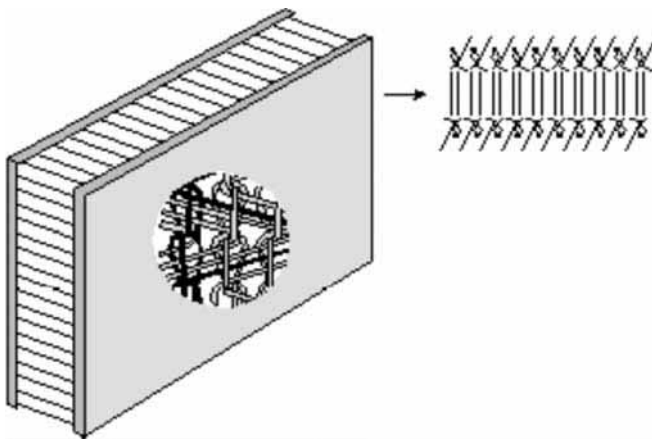
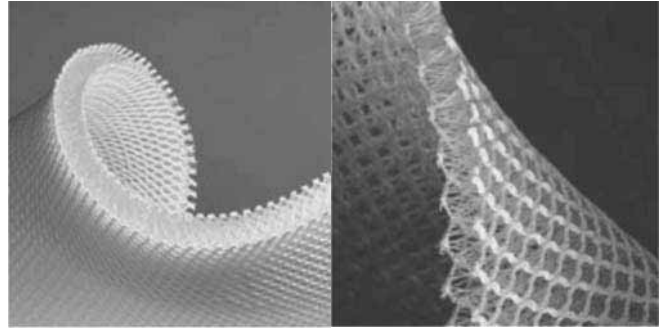

Fig. 2.2 3D Warp Knitted Structures

2.2.1 Spacer fabric

Spacer structure is knitted fabric construction comprising two separate fabric webs, which are joined together by spacer threads or fibres of varying rigidity. The intermediate zone creates a layer of air, which has an insulating and thermoregulatory effect. Modifying the structure of the knitted construction can alter the amount of air incorporated in the assembly.



Cross Sectional view of Warp Knitted Spacer Fabric

The yarn material used to join the plain ground fabric at the front side and the plain ground fabric at the backside with a defined “space” is mostly a stable, pressure tolerant material. Spacer fabrics are breathable, resilient, flexible, and soft. They come in a variety of weights, colors, textures, and designs.

2.2.2 Tubular Warp Knits

Tubular warp knits are of two type- horizontal and vertical. Horizontal tubes are produced on double needle bar machines by first knitting two separate fabrics on two needle bars and then knitting one combined fabric on both bars.

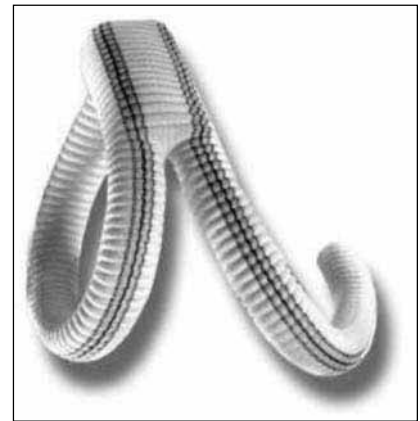

Horizontal packing sacks suitable for manual packing or automatic packing machines are easily made this way. With the appropriate fabric structure, different quantities of different products are safely packed in these knitted sacks.

Vertical tubes are produced by knitting separate fabric lengths on each needle bar, which are joined at the edges. By using patterning devices, the tubular length is knitted close and then open at specified intervals, just as it is possible to alternate from one tubular construction to several smaller ones at specified intervals.

Typical products manufactured in this technique are tubular packaging nets for fruit, vegetables, nuts, packaging sacks for potatoes and onions, elastic tubular construction for salami and ham. Warp knitted rescue tubes made this way have proved best for rescuing

peoples trapped in burning skyscrapers. Branched tubular structures can also be made. Branched artificial blood arteries are produced on a fine double needle bar Raschel machine.

Flexible water pipes are made from coil shaped warp knitted strip which is embedded in plastic. The warp knitted construction ensures the necessary compressive strength and the plastic guarantees that system is waterproof.

2.3 Directionally Oriented Structure

Directionally oriented structures or DOS are unique fabrics which are produced only by warp knitting techniques. With this technique, straight ends of absolutely parallel and uncrimped yarns are inlaid into the structure at almost any desirable angle.

Fabric characteristics are engineered to enhance the in-plane properties only in the required orientation so that the fabric produced has the ideal combination of excellent mechanical properties and a favorable production cost. DOS fabrics are divided into three main groups- monoaxial, biaxial and multiaxial.

DOS fabrics have following good properties-

- Optimum yarn strength utilization
- High tear propagation resistance, which is important for safety
- Good adhesion property
- No fraying of cut selvedge
- Slip resistance fabric structure
- Economical production.

2.3.1 Monoaxial Structure

Load bearing yarns in these structures are either in warp or in weft direction. In the direction chosen the strength is very high and the dimensional stability is absolute, where the other direction has only limited stability. This type of fabric is often used in the geo-technical sector, textile reinforced adhesive tapes, simple laminate and membrane substrates filter for rubber industry and in machine as dialysis filters.

2.3.2 Biaxial Structure

As the name implies, load-bearing inlaid yarns run in two directions – vertically and horizontally. The intersection points are secured by knitted stitches. Recently it has become possible to manufacture biaxial structures with the inland yarns arranged diagonally at an angle between 30° and 60°.

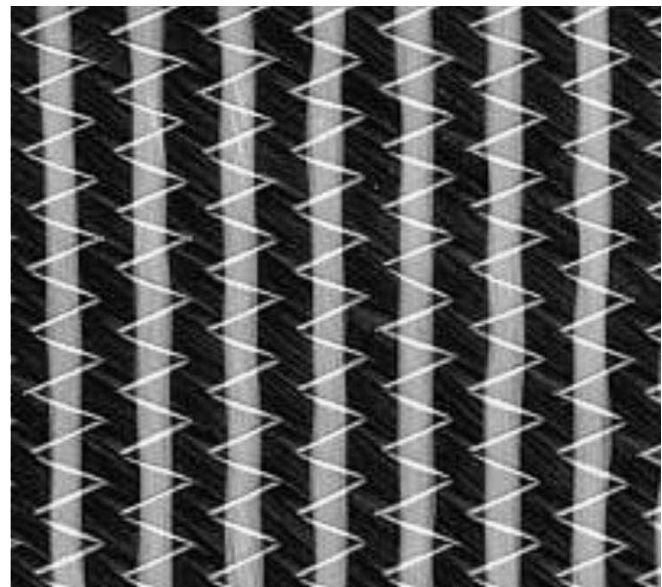

Fig. 2.3 Monoaxial Structure

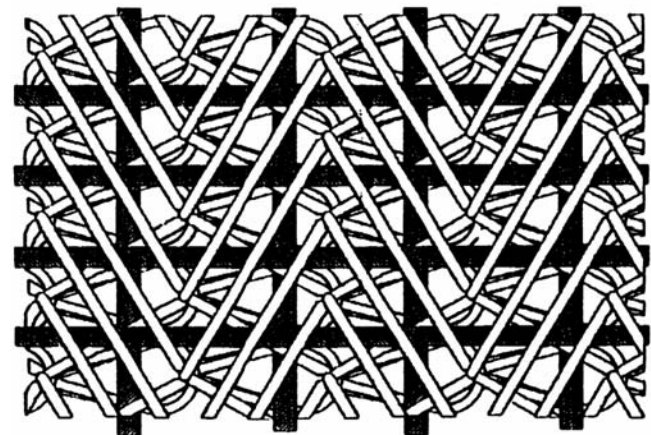

Fig. 2.4 Biaxial Structure

2.3.3 Multiaxial Structure

In the multiaxial structures, four yarn layers are placed in perfect order each on top of the other. Each layer has the uniformity of the uncrimped parallel yarns.

In the area of the so called hi-tech textiles, multiaxial structures are used in the areas of amongst others, mechanical engineering, vehicle construction, ship and boat building, aircraft construction, ballistics and power plant construction. In these cases warp knitted multiaxial structures are used as strength carriers consisting of glass fibre, carbon fibre, aramid and hi-strength polyester yarns with epoxy, polyester or phenolic resins. The advantages of warp knitted multiaxial structures from high performance fibres are low weight, high strength and good resin absorption. Following paragraphs show the application details.

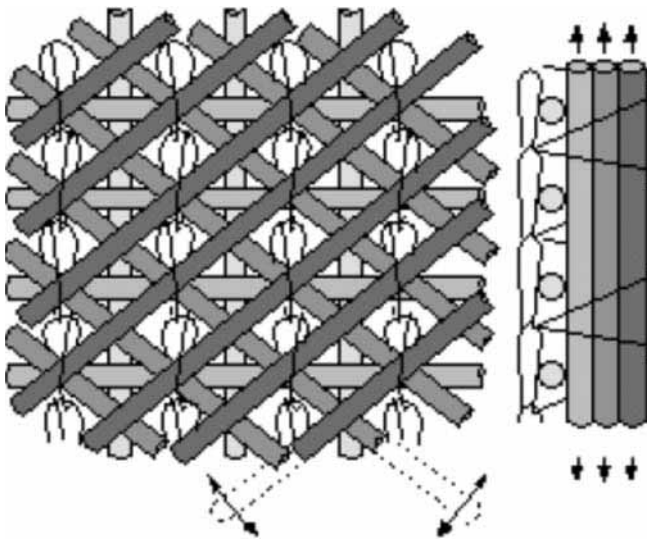

Fig. 2.5 Multi-axial Structure

Mechanical engineering: rotating spindles, light weight building equipment panel, support section.

Vehicle construction: bonnets and boots, floor panels, container superstructures, light arm pouring for civil, police and military sectors.

Ship and boat building: high performance hulls, deck superstructures, components of sailing yachts and racing canoes predominantly made from glass fibre yarns with non woven or aramid yarn reinforcement.

Aircraft construction: top and side tail units, fuselage paneling leading edges on side rudders, engine paneling, propellers. These are made from glass/carbon fibre combinations, carbon fibres, aramid fibres and high tenacity polyester. For the construction of helicopter multi-axial structures are used for the rotor blades, outer paneling and armoring with carbon fibre/aramid yarns. For spacecraft, rocket, motor housings are made from carbon fibre/ aramid yarn multi-axial structures.

Ballistics: helmets, protective jackets, splinter proof protection suits, armoring for vehicles and building from aramid yarns in combination with carbon fibre yarns.

Energy plants: wings/propellers for wind power plants from glass fibre yarns.

Covering systems: light weight tarpaulin, air-pipes in mining, light weight balloon fabrics for hot air and captive balloons, air cushions made from high tenacity polyester.

Rubber industry: flat belts, drive belts, fan belts and toothed belts, conveyor belts, tyre cord fabrics, high performance rubber dinghies, inflatable life-rafts and inflatable cushion.

Geo textiles: reinforcement of non woven fabrics used as soil layer separation fabrics or for filtration.

2.4 Composite Structures

Composite fabrics are also unique constructions which are produced, on warp knitting machines. Each construction is a combination of at least two fabric components which are produced as a composite in one operation and which have a greater performance than the components on their own. With all other textile manufacturing methods the substrate components are produced individually and are combined by adhesive, thermo bonding or sewing processes. There are special warp knitting machines in which the composite fabric is produced in a single, simple and very productive operation. The most popular composite fabrics are DOS-reinforced non-woven composite which are mono-axial, bi-axial and multi-axial.

The advantages of DOS-reinforced non-woven fleece are-

- Improved coating operation (for tarpaulins)
- Improved insulation (flat roof covering)
- Improved mechanical properties, except tear resistance (composite technical textiles)
- Better filtration and reinforcements (geo textiles)

Flat roofing material and tarpaulins of very good quality are made from bi-axial composites. Sports hall floor covering is one of the end-use of multi-axial composites. Among the required properties are the multidirectional distribution of forces, high tensile strength, high tear resistance, excellent coating material distribution and cohesion.

According to current developments, body parts of cars are not joined together, they are combined into a complete composite shell. Current end uses for car composite material include: side doors, bonnets, roof, dashboards supports, seats, headlining, rear side parts, rear hatches, front fenders, valve covers, oil pans and supporting composite frames.

In aviation, 15% of the skin of Airbus is made of composite materials. The tail unit is made of composite fabrics made from carbon fibre. Apart from the

horizontal and vertical stabilizer and elevators, composite material are also used in aeroplanes and helicopters for air brakes, noses, steadying studs, rotor blades wings and the fuselage.

In mechanical engineering composite fabric are used for machine tool spindles, grinding spindles, robot arms and cog wheels. Ability of the composite material to mould into any shape and its light weight are certain to make new developments in this sector.

3. Area-wise Application of Warp Knitted Structure

3.1 Industrial Textiles

The following types of warp knitted products are grouped together under the generic term “industrial fabrics”[3].

- (a) Nets for fishing and marine culture
- (b) Plants and harvesting nets
- (c) Conveyor fabrics
- (d) Nets for foodstuffs
- (e) Filter fabrics.

Each of this type is now discussed briefly to provide some understanding of their potential for manufacturing by warp knitting.

3.1.1 Nets for Fishing and Marine Culture

Nets for fishing and marine culture include conical and large fish pots, catch nets, spoon nets, small and large landing nets, dragnets and ring nets.

Fishing nets are produced on Raschel machine [4] with width from 267 cm to 483 cm and gauges of 2.7 to 6.3 needles per cm (npc) in which nylon and polypropylene yarns of 200 to 1500 dtex are used. These nets have the decisive advantage of being knot-free, i.e. the crossing points are not fixed by knots but by loops so that the net does not slip about and has the same width at all time.



Fig. 3.1 Fishing Net

3.1.2 Plants and Harvesting Nets

Plants and harvesting nets are used to increase agricultural yields. Nets are used to stop fruit from rotting on, damp soil or from falling off. This type of net is produced on Raschel machine [4] with working width of 191 cm to 660 cm and gauges of 2.36 npc. The production rate is in the region of 120 m/hour. The yarns used are polyethylene or polypropylene tape yarns.



Fig. 3.2 Plant Net

3.1.3 Conveyor Fabrics

Warp knitted fabric with net like structure or dense constructions may be used as carrier materials to give the product laminated to them the required strength or to fix several pieces together using a carrier net. The advantage of the warp knitting process is to produce slip resistance in the fabric even with very open construction. These fabrics are produced on Mayer Raschel machine and are used as mosaic carrier nets or reinforcing nets. Machine gauges of 2.36 npc to 4.72 npc are used and produced from polypropylene or polyethylene tape yarns in the case of reinforcing nets. Carrier fabrics for artificial leather are produced on Mayer KS2, KS3 or KS4 Tricot machines and subsequently coated with PVC or polyurethane.

3.1.4 Nets for Foodstuffs

Nets for foods tuffs are elasticated Raschel knitted tubular nets used for covering salami sausages and bacon and are produced on double needle bar Raschel machines in a gauge of 1.18 npc [5].

3.1.5 Filter Fabrics

Filter fabrics are used in the chemical industry as petrol, oil and air filters in motor vehicles, or as fluff-filters in washing machines that are produced on various Tricot and Raschel machines. The type of machine, gauge, and yarns used would depend on the density of the fabric and the resistance required against filtering liquids. The advantages of warp knitted filter fabrics is

their perfectly uniform openings which as previously stated are guaranteed by the slip resistance nature of the fabric. For instance, a fluff filter is produced on Mayer HKS2 [5] Tricot machine with a gauge of 11.0 npc and width of 213 cm to 522 cm using 22 dtex nylon yarn.

3.2 Medical Textiles

Based on a large number of experiments long term trials and clinical examinations, it was unanimously stated and concluded that “Dacron” called polyester synthetic yarns are the most adequate textile materials for the human medical articles [6].

Textile yarns used for medical purposes have the following characteristics:-

- High resistance to micro-organisms
- High resistance to acids
- Good resistance to alkali
- Very good dimensional stability (high crease resistance, maintaining of texturing and embossing effects)
- High elasticity modulus
- As good as possible polymer weight
- No metallic traces and especially lead traces
- Can be as clean as possible (very well scoured).

For the manufacturing of medical articles, polyester filament yarns as compared to other synthetic yarns present a greater interest as regards the contact with the human body tissues due to their chemical stability in aqueous medium, in air, as well as due to the absence of the biological activity.

So far, several types of warp knitted textile products have been developed for specialized medical applications. They are broadly classified as [7].

3.2.1 Implantable Textiles

3.2.1.1 Vascular Prostheses [6]

Among the implantable textiles, vascular prostheses are more common and are in great demand. Different types of prostheses have been tried and developed. Warp knitted vascular prostheses are now available in market in standard weights and in ultra light weights. This graft has a high porosity which allows in-growth of fibrous tissues and strong adherence to the tissues. It needs to be protected prior to use to avoid bleeding.

Vascular prostheses are knitted on special high gauge knitting machines. The Tricot structure as well as the

technological working parameters ensure an optimal porosity of the artery walls and minimize bleeding their water permeability ranging from 400-650 cm³ / cm² min⁻¹. Knitting of vascular prostheses made of stretched and finer filament yarns also requires the reviewing of their technical and technological processing conditions.

3.2.1.2 Vascular Bioprostheses [6]

Vascular prosthesis is made of a human umbilical covered with textile knitted mesh. It can be used with good results in-

- Artery repair
- Vein repair - Romanian priority
- Artery - vein shunting for extra renal dialysis.

The textile part of the vascular bioprostheses is made from a “Plastex” type mesh knitted fabric. The knitted fabric is consolidated on a biological material in the Fundeni, Cardiovascular Surgery Clinic by means of a special sewing thread developed in the Textile Research Institute. The Structure of the Tricot helps in maintaining shape and prevents the obstructions on the umbilical cord tract.

3.2.1.3 Cardiac Biological Valves [6]

Biological valves consist of a buttress and a biological part which is the so called valve. The buttress consists of a polypropylene frame covered with a polyester warp knitted fabric. The knitted fabric has the following characteristics:

- Inactive to human body
- High bursting resistance
- Extremely high moulding capacity
- Remarkable compactness
- Extremely low unraveling capacity

The knitted fabric is made of 50/20 dtex textured polyester yarns in a double Tricot structure, 20-30 courses per cm processed on a 28-32 gauge warp knitting machine.

Tricot covering of the plastic support is a manual operation of a complex and skillful character and in order to obtain high quality products at the level of the medical requirements, this operation must be strictly considered with respect to the quality of the material and the quality and consciousness of the work done. The biological part is taken from the wild boar and after a complex preparing process it is sewn-fixed in the support. The supports, respectively the valves are produced and delivered in special containers in nine

size types with an implanting diameter of 7, 17, 19, 21, 23, 25, 27, 29, 31 and 33 cm.

3.2.1.4 Vascular Graft Patches and Tubes [7]

Apart from vascular prostheses, a wide range of warp knitted tubes, bifurcated graft and patch materials in different dimensions including straight, crimped, conical and non-compressible types, multi-channel bifurcated and polyfurcated prostheses have also been developed. Recent artificial grafts for various prostheses are available in crimped structures, their inner surface being flat, while the outer surface is in the form of a loop to promote tissue in growth. Knitted tubes have also been developed for supracoronary grafts as shown in fig 3.3. They are also available in the form of sewing rings for all kinds of mechanical heart valves.

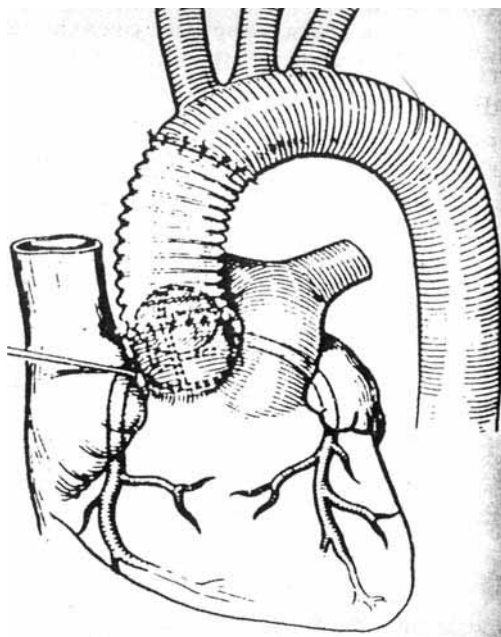

Fig. 3.3. Bifurcated Knitted Vascular Prostheses

3.2.1.5 Surgical Meshes and Membrane [7]

Suspensory and reinforcing surgical meshes are largely used in the treatment of hernia, in urology, gynaecology and so on. Fine warp knitted meshes made out of polyester are used mainly for covering the duramater defects. This fabric is embedded into a glycomethacrylate gel which creates a smooth surface on both sides of the mesh.

Recently Mitsubishi Rayon Co. Ltd has invented a special technique to incorporate bundles of hollow fibre into a membrane module, using warp knitting technique. These membranes have been successfully tried in artificial lungs, dialysis, plasmapheresis and in filtration.

3.2.2 Dressings [6]

Now-a-days apart from woven dressing, knitted dressing is also gaining growing popularity due to the following advantages such as-

- Easy handling
- Better Hydrophobicity
- High porosity, and
- Flexibility.

The Kendall Inc. of USA has developed an elasticated bandage made from a warp knitted fabric with texture floating warp threads and non-elastic weft threads which are distributed in a regular, repeating pattern across the bandage.



Fig. 3.4 Medical Bandages

Another warp knitted bandage cloth developed by M/s Medimawerka of Germany is made of elasticated material extending in the wale direction which is interlaced in the course direction with Tricot threads. In order to obtain a controlled horizontal elasticity, their pillar stitch thread always crosses one wale to another wale, where it forms at least one stitch.

3.3 Geo Textiles [8]

Geo textiles form a large sub-section in the technical textiles sector. In construction engineering, they are used in underground structures for soil and slope stabilization, drainage, erosion protection and for reinforcement and sealing of asphalt in road construction. A substantial volume of geo textiles are warp knitted structures with or without non-woven fleece.

Quite large quantities of warp knitted fabrics are used for geo textile applications such as building foundation, drainage layers, railway construction, marine wave defense, landscape protection etc. with respect to the properties such as tensile properties, tear strength, hydraulic properties as warp knitted geo textiles are advantageous when compared to others. Fabric/soil shear and fabric/soil friction characteristics of warp knitted geo textiles ensure better performance than others.

For the application of geo textiles for filtration purpose, the geo textile must hold up the solid face of the soil, permitting water within the soil to drain out without liquefying the soil and without achieving sufficient exit velocity. A warp knitted biaxial structure is suitable for this purpose in which mesh size of the fabric are matched with the type of soil.

3.3.1 Vertical Walls

Warp knitted DOS geo textile are utilized and thus prevent the collapse of steep embankment faces and vertical retaining walls. DOS structure is preferred for these applications. The uncrimped yarn arrangement in the fabric ensures that the stress generated in the soil will be transmitted directly to the high tenacity polymer without any straightening of the textile structure resulting in minimized movement of the geostructure.

3.3.2 Drainage and Filtration

In such application, the geo textile does not filter the soil, but supports the exposed soil surface preventing it from breakdown.

A simple combination of pillar stitch and inserted weft produces fine net. The absolute uniformity of the opening enables the civil engineer to select the correct fabric for the soil particle distribution.

3.3.3 Steep Embankments

Directionally structured fibre (DSF) geotextiles are used as reinforcement within soil, where soil is formed into embankments or steep slopes. The bulk of the structure is made of inlaid yarns so that fabric weight is kept down and the yarn is placed to work in the correct orientation. Raschel machine is used for the production of such structures, equipped with limited number of guide bars.

3.3.4 Fin Drains

It is a composite polymer drain in the form of a vertical

sheet. It is permeable to water and is designed to conduct water along its length. Three dimensional cusped honeycomb textiles can be used as the permeable core in the drain. Basic Tricot machine is used for production of this structure.

3.3.5 River and Marine Erosion Protection

Geo textiles are used beneath the stone or concrete facing the river banks and canals to prevent erosion where water currents and waves would wash out the fine soil particles. The use of geotextiles by means of heavier grade materials is extended into erosion control structure in tidal estuaries and even on coastal zones facing direct attack by large waves. Composite DOS structure is used in the construction. Raschel machine is preferable for this structure.

3.3.6 Embankment Support

With embankment construction, local, underlying cohesive soil may be protected from failure by geotextile reinforcement. A very special fabric is used in embankment supports. Raschel machine is preferred in this case.

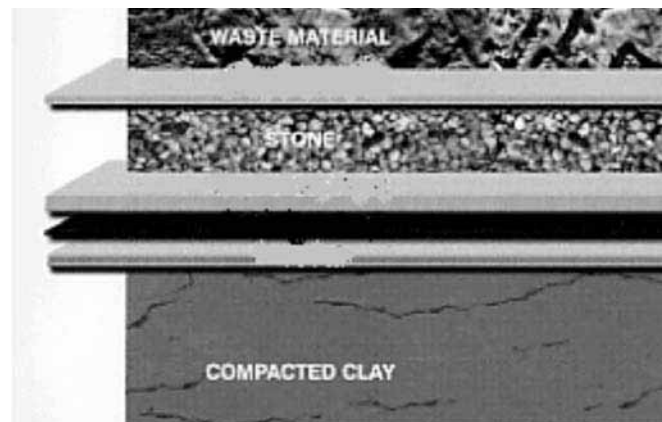

Fig. 3.5 Geo textile

Apart from the above applications warp knitted geo textiles also used for high speed rail network where a stable foundation for railway lines is very important. A complete biaxial DOS structure with non woven is used as an intermediate layer in roadbed construction for rail lines.

In road building and road repair, geo textiles have been used successfully for many years to prevent "reflection cracking" (crack propagation from the old into new road surface). Composite biaxial polyester or polypropylene DOS structure with polyester non-wovens are used as inserts in asphalt or concrete

layers. These asphalt reinforcements are laid between any layer and depending on the end-use sector, have different task. The geo textile are inserted when a new road is built or during repairs.

3.4 Agrotech Textiles

An estimate of 45,000 tones consumption of knitted agrotexiles has been made by the European market, which is the leading market and main consumer of technical usage knits. Warp knitted protective nets are used in different sectors which are produced on Raschel machine. Agro nets are produced in various constructions or lapping. Here, the construction or lapping is the way in which individual yarn systems are converted into fabrics. For protective nets a chain is usually combined with an inlay or a two-needle under lap construction i.e. two guide bars are necessary for producing agro net.

The major applications of knitted nets are in the area of packing of hay-bales, nets for protection against birds, wind and insects etc, anti hail nets, shading nets, support nets for climbing flowers and vegetables, nets for fruit collection etc. Detailed construction, fibre used and other characteristics of warp knitted agrotexiles given in Table 3.1.

3.4.1 Windbreaker Nets [9]

The wind breaker net is to filter the wind passage but not to stop it entirely. This is because when wind meet an airtight barrier, it is deviated upwards; the air duct passage being thus reduced, the flow speed increases and creates a turbulence that is harmful to the protected crops. In the case of a permeable barrier, a windbreaker, part of the airflow passes through it thus reducing the turbulence phenomenon.

3.4.2 Monofil Nets

Monofilaments warp knitted nets are most commonly used as windbreaks - protecting crops against wind damage, frost and dehydration. The nets are also designed to withstand the impact of heavy hailstorms, when installed in roof-profile above crops and may be used to provide shade and frost protection as well. The range of pre-stressed, UV stabilized polyethylene knitted nets are available in black, white or environmental green, with a choice of standard roll widths. They have reinforced edges and intermediate strips, incorporating eyelets for fixing.

Table 3.1 Fibre used and Fabric Constructional Parameters of Different Warp Knitted Agrotexiles

| Area of application | Fibre type | Yarn particulars | Other characteristics |
|---------------------|---------------------------|---|---|
| Sunscreen | Polypropylene | Monofilament of 0.15-0.30 mm diameter | Mesh size - depends on shade%,40-80gsm |
| | Polyethylene | Tape yarn of 2-3mm width and 0.025mm thick | Mesh size – depends on shade %, 40-80 gsm |
| Bird protection | Polypropylene 0.15 - 0.30 | Monofilament of mm diameter | Mesh size – depends on shade %, 40 - 80 gsm. |
| | Polyethylene | Tape yarn of 2 mm width and 0.025 mm thickness | Mesh size – depends on shade%, 40 - 80 gsm. |
| Plant net | Polypropylene | Monofilament of 0.15 - 0.30 mm diameter | Staple strips of net with large holes, 30-40 gsm |
| | Polyethylene | Tape yarn of 2-3 mm width and 0.025 mm thickness | Staple strips of net with large holes, 30-40 gsm |
| Harvesting | Polypropylene | Monofilament of 0.15 - 0.30 mm diameter | Flat nets of square and triangular construction, mesh size 8-12 cm,40-90 gsm |
| | Polyethylene | Tape yarn of 2-3 mm width and 0.025 mm thickness | Flat nets of square and triangular construction, mesh size 8-12 cm, 40-90 gsm |
| Windshield | Polypropylene | Monofilament of 0.15 - 0.30 mm diameter | Mesh size – depends on shade%, 40 - 80 gsm. |
| Root balls of Plant | Polyethylene | Tape yarn of 2-3 mm width and 0.025 mm thickness | Mesh size – large or small |
| | Nylon/PET and Spandex | Monofilament | Elastic tubular net |
| Turf Protection | Polyethylene | Tape yarn of 2-3 mm width and 0.025 mm thickness | Flat net with an open structure, 30-40 gsm. |
| Packaging material | Polyethylene | Tape yarn of 2-3 mm width and 0.025 mm thickness. | 50 - 60 gsm |
| Pest control fabric | Polypropylene | | Light permeability - 92 % 17 gsm |

3.4.3 Tape Nets

Certain crops need shade. For this purpose a number of tape nets, with shade values of ranging from 50% to 80% have been developed. Because of the reduced weight of the nets they are laid directly onto the plants. They can also be used for frost protection.

3.4.4 Bird net

The black, warp knitted, open nets protect crops against damage caused by birds, squirrels and a variety of rodents. Their construction allows them to conform to irregular shapes and because they are so light are draped directly over the crops. The nets are UV stabilized so will offer many years of service.

3.4.5 Insect meshes [10]

Control of insect pests by the use of selective mesh screens reduces the need for insecticide use. Insect meshes may be used for a range of purposes, including loose covers or rigid screens for field crops, screens for glasshouse doors and windows, internal sections for green houses and tunnel covers. The selection of insect screens which are available in various mesh sizes, depends upon the insect species to be excluded and the percentage of ventilation reduction permissible.

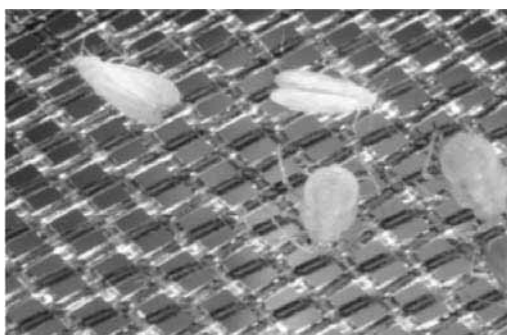

Fig. 3.6 Warp Knitted Insect Net

3.5 Home Textile

This mainly includes curtains and table clothes, furnishing fabrics, decorative fabrics and light weight net curtain. Special functional properties of such warp knitted fabrics ensure weathering resistance [8].

Numerous fabrics are used in the household sector, such as dish cloths, floor-clothes; furnishing cloth for example, must absorb moisture quickly and therefore utilize extremely thick and soft weft yarns. These fabrics are produced on Mayer Raschel machine which has two guide bars and multi-width weft insertion with machine gauge of 2.36 npc. Compared with other techniques, Raschel knitting is characterized by its high

production rates, low production costs and durability of the products, due to locking-in of the thick absorbent yarns by relatively finer threads in the pillar stitches.

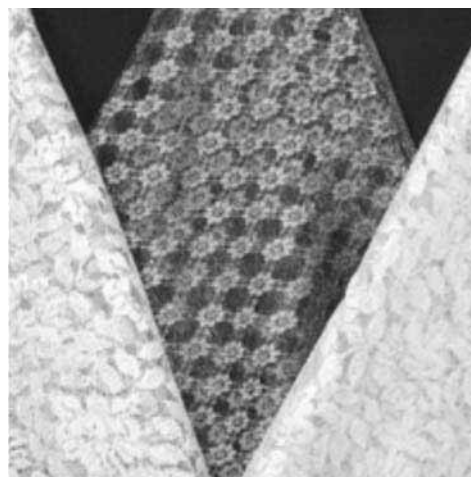

Fig. 3.7 Warp Knitted Decorative Fabric

3.6 Sports Textile

Raschel knitted products have found important outlets in the sports and leisure sectors [5]. They are used for wind breaks, hammocks, floor mats, tennis nets, training nets for tennis and golf and horse blankets. Most of these products are also produced on Mayer R4N machines with a gauge of 2.36 npc, in the case of hammocks, which are produced from polyethylene or polypropylene tape yarns.

MALIMO Multiaxial [10] is a high-tech knitting machine with several weft insertion system for the production of multiaxial fabric layer used for various applications such as tennis racquets, skis, snowboards, surfboards, sport boats etc.

Spacer fabrics are widely used in sportswear such as surf jackets, submerses for diving suits, functional jackets and protection areas in sportswear, breathable shoe fabrics.

3.7 Protective Textile

Protective, safety and growing nets are Raschel knitted and are used as protection and safety means, as well as land reclamation. Such nets are used for protecting turf for example, by stretching the net across the ground so that grazing animals can not pull out the turf, thus ensuring that the grass is not destroyed by grazing. These open net are produced on Mayer R4N Raschel machine with the working width of 191 cm to 660 cm and a gauge of 2.36 npc. In this case 2-3 mm x 0.025 mm polyethylene or polypropylene tape yarns are used.

Other end uses include bird netting, mosquito netting, rock retaining nets, camouflage nets, awnings antidazzle nets, rescue nets, such as those used for aircraft escape slides produced by warp knitted high tenacity filament yarns. The warp thread runs in the direction of the slide, the fabric is constructed in the form of a net and yarns are inlaid in the structure to form the warp threads, and the weft threads inserted across the full width. The structure is also combined with a woven cloth during knitting which acts as a support.

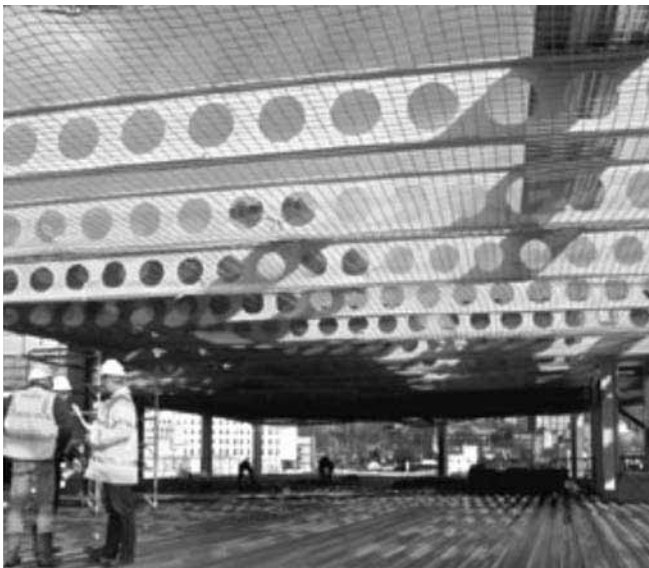

Fig. 3.8 Warp Knitted Safety Net

3.8 Packaging Textiles

Packing materials are usually Raschel knitted nets produced on a double needle bar machine from tape yarns which give better cover and result in a lower surface pressure than yarn with a circular cross section. The main end use is packing sacs for potatoes, citrus fruits, onions and vegetables. These are produced with an open construction on Mayer HDR 10 EHW-ST double needle bar Raschel machine in width of 267 cm to 432 cm and a gauge of 2.36 npc. The yarn used to make this type of fabric is 2-3 mm x 0.025 mm polyethylene or polypropylene tape yarns, sometimes reinforced with polypropylene monofilaments. The other types are tubular packing nets, packing and camping bags, melon nets, coated packing sacks, laundry and dyeing bags and container nets.

3.9 Automotive Textiles

The other areas of application are in the communication technology but the largest end-use is in the transport sector and for years warp knitted fabrics have been successfully used for the interior furnishing of vehicles.

The uses of warp knitted textile in the field of automotive industry are of the following -

3.9.1 Seat Covering Fabrics

For these applications, fabric can be [11]-

- Flat with slight relief or raised or with surface patterning
- Velour fabrics, plain or with surface patterns.

The machine used for such structures are Tricot machine, pile jacquard Tricot machine, double plush Raschel machine.

3.9.2 Decorative Cladding

This sector especially includes covering for around the seat base and back, door panels, head-liners, support pillars for the door and windows and parcel shelves.

For these applications, fabric construction is:

- Flat with slight relief or raised or with surface patterning
- Velour fabrics, plain or with surface patterns.
- Spacer fabric with or without decorative side
- Fleece fabric with light surface pattern effects.

The machine used for such structures are Tricot, machines pile jacquard Tricot machine, double plush Raschel machine.

3.9.3 Substitute for Foam Laminates and Upholstery Backing

The decorative textiles for seat covering and upholstery sectors were previously coated with foam fabric, which was covered on the reverse side with a smooth base fabric. The demand for single material sourcing to facilitate recycling and the urgent need to replace foam requires alternative constructions.

For these applications, fabric construction can be [12]-

- Spacer fabric with plain surface
- Compact fleece fabric
- Voluminous fleece fabric

The machine used for such structure is double plush Raschel machine.

3.9.4 Matting

Includes covering for interior floor and in luggage compartments. For these applications, fabric construction of the fabric is [13]-

- Ground fabric with pile loops
- Velour plain or with mélange effect

The machines used for such structures are Tricot machine with or without pile device, double plush Raschel machine.

3.10 Building Textiles

This mainly comprises of fabrics for building industry, plaster base, waterproof sheeting for roofs. Light weight supporting frame works, air inflated tents, stadium roofing, and flat-roof coverings and face insulations are also done using textiles. For these applications, warp knitted structures are successfully applicable [14].

Architectural textiles made from biaxial structures are used to cover swimming pools in winter or as canopies for shopping centres, tennis courts, fun parks, sport ground etc. The unconventional nature of these structures makes them pleasantly different from rigid brick and concrete buildings. Polyester, nylon and glass fibre yarns are used. The fabric is coated with PVC, urethane, polyacrylic and silicon to reduce its air and water permeability and to increase its durability.

The warp knitting industry has practically revolutionalised the market for flat roofing materials. For durably covering flat roofs on factories and shopping centres, on private houses and commercial properties, biaxial warp knitted fabric are coated with elastomers, PVC etc. to make them waterproof and resistance to environmental influences.

Another product with large market volume is lorry tarpaulins, which are made from vinyl coated biaxial warp knitted fabric made from nylon and polyester.

Tarpaulin for the construction, industrial and household sectors are also made similarly.

High performance sails are made from a laminated biaxial warp knitted structure. Biaxial fabrics are also used as high performance prepegs in aerospace and aircraft applications, in the automotive industry for making conveyor belts. The longest conveyor belt in the world, installed in the port of Rotterdam, is a biaxially knitted fabric with aramid fibres of approximately 9300 tex in the warp.

3.11 Warp Knitted Clothtech

Technical portion of the cloth which does not serve aesthetic property but some special technical properties is known as clothtech. Short-term market modifications, quickly changing fashion cycle, ever increasing variety of articles and smaller quantities of orders require highest flexibility. These prerequisites are fulfilled by warp knitter in a quick and economical manner. Only by means of new guide bar control it is possible to produce lapping with almost unlimited repeat lengths and of highest technical difficulty.

One of the main applications in this field is lace fabric. The basic application of the lace products is for the doll clothes edge, socks edge, female underwear, underclothes, such as bras, underpants, nightclothes, etc. Due to the varied fashion styles, the laces are also applicable to embossing, shoes, jeans, etc.

The new generation of lace machines has even surpassed the pattern possibilities and has set new standards in terms of the technology and variety of designs that are produced leading to greater differentiation in terms of lace production.

TAI BOOK PUBLICATIONS

Book your orders with:

THE TEXTILE ASSOCIATION (INDIA) - Central Office

Pathare House, Next to State Bank of India,
67, Ranade Road, Dadar (W),
Mumbai – 400 028

Tel.: 022-2446 1145, Fax: 022-2447 4974

Orders accepted by E-Mail: taicnt@mtnl.net.in

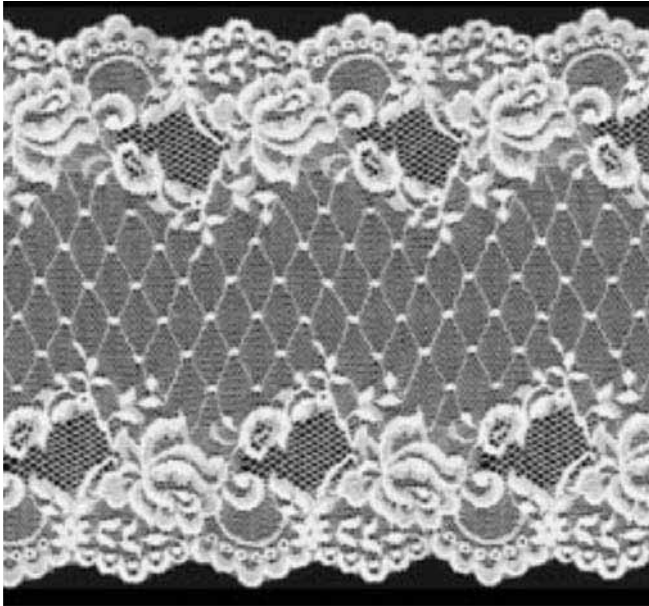

Fig. 3.9 Warp Knitted Lace Fabric

References

1. Spencer, D.J., *Knitting Technology*, Woodhead Publishing Limited, Cambridge, England, 393 (2001)
2. Roy A. K., *Knitting Industry Centenary International Conference Papers*, New Delhi, 255 (1993)
3. Anand.S.C. Lawton P.J. Burnip M.S. *29th International Federation of Knitting Technologists Congress*, IIT Delhi, India, 324 (1985)
4. www.karlmayer.de
5. Darlington, K.D. *Knitting International*, 82 (4) 252 (1975)
6. Dodu. A. et. al. *29th International Federation of Knitting Technologists Congress*, IIT Delhi, India, 122 (1985)
7. Bala. S.K., Siddhartha, *Knitting Industry Centenary International Conference Paper*, New Delhi, India, 133 (1993)
8. Anon, *The Indian Textile Journal*. CXXI (4), 153 (2005)
9. Sankhe Manoj, Chitnis R S, *The Indian Textile Journal*, CXIII (3), (2001)
10. <http://www.clo.fgov.be/dvl/agrotextiles.htm>
11. Smith, J. *Knitting International*, 84 (10), 35 (1977)
12. Wilkens, C. *Knitting International*, 87 (1), 71 (1980)
13. Anon, *Knitting International*, 84 (10), 132 (1977)
14. A. Peled and A. Bentur, *Materials and Structures*, 31 (8), 543 (1998).



The Textile Association (India) *Cordially invites you all*

The visit the stall of
Journal of the
 **TEXTILE ASSOCIATION**

At
ITMA 2011 – International Exhibition of Textile
and Garment Machinery
Date: 22nd to 29th September, 2011
Venue: Fira de Barcelona Gran Via, Spain

Visit us:
Hall No.
Stall No.



E-control-The Ecofriendly Process

Ajinkya Khot, Chandrakant Lende*

Textile Department, ICT

Abstract

The rapid increase in demand of reactive dyestuff is due to their excellent wet fastness and simple dyeing operation. Reactive dyestuff can be applied by various traditional processes but these consume a considerable amount of energy, water and chemicals. Due to increasing demand for woven and knitted fabrics, energy consumed in reactive dyeing processes is increased. It has become necessary to look for energy efficient techniques which use less energy, water, chemicals etc. Use of more water in washing requirements leads to more effluent and effluent disposal becomes more concern. This paper is mainly focussing on basic principle and recommended dyes for E-control process. In this process, the reactivity of the dyestuff is exploited together with the drying behaviour of the fabric in such a way that optimum colour yields can be achieved without the use of large and aggressive volumes of alkali. Hence, it is eco-friendly and economical. This E-control process is also an energy efficient technique as it is a combination of continuous batch process and drying process.

Key words

E-control, Reactive Dyestuff, Eco-friendly process

1. Introduction

The continuous dyeing of cotton using reactive dye is gaining importance over the traditional batchwise techniques owing to the major advantages in terms of uniformity of shades in long yardages, high productivity, low utility cost in terms of consumption of dyes, chemicals, water, energy and low effluent generation. Continuous dyeing provides fabrics with a uniform visual appearance, freedom from creasing [1]. Recently, there are changes in the dyeing process of cellulose using reactive dyestuff by continuous application. There are so many factors for such changes.

Some of these factors are:

- The need of superior quality
- Ecofriendly application method
- Cost reduction by minimising the use of energy and water
- Quick response through “right first time”[2].

Considering such a factor, effective coordination between a dyestuff manufacturer, textile processor, machinery producer has lead to ongoing improvements in the continuous dyeing process of cellulose using

reactive dyestuff. Various dyeing methods are adopted depending upon the type of substrate, selection of dye, availability of machinery and processors choice.

Adopted reactive dyeing methods include various processes such as Pad (with alkali) – batch, Pad (with alkali) - dry -thermofix process, Pad (with alkali) - steam process, Pad (dye) - dry- pad (with alkali) - steam process. But, in these processes, sodium hydroxide, water, soda ash, urea and salt are the chemicals which are used in large quantities. Hence, chemicals are discharged partly with the exhaust air and the most part contaminate the waste water during washing off. For controlling environmental pollution, avoidance is always the best solution, because, avoidance results in to minimum material handling and minimum water pollution [3]. Avoidance of high alkali, urea and salt consumption is possible as the E-control process functions without these chemicals. This means that E-control process contributes significantly to environment pollution control.

This article gives detailed information about the E-control dyeing process i.e. we are concentrating on its basic principle and possible shades, its dye and fibre requirements. As it is more economical, energy saving and ecofriendly, it has been commercialised.

*Correspondance should be addressed to,

Chandrakant Lende

Room no. 79, Old Hostel no.1,

ICT, Matunga, Mumbai

E-mail: chandrakantlende26@gmail.com

2. Process

In continuous dyeing of woven cellulosic fabrics using reactive dyestuffs, several variations are possible such as (Fig 2.1):

1. Pad (with alkali) - batch.
2. Pad (with alkali) - dry -thermofixing process.
3. Pad (with alkali) - steam process.
4. Pad (dye) - dry- pad (with alkali) - steam process.

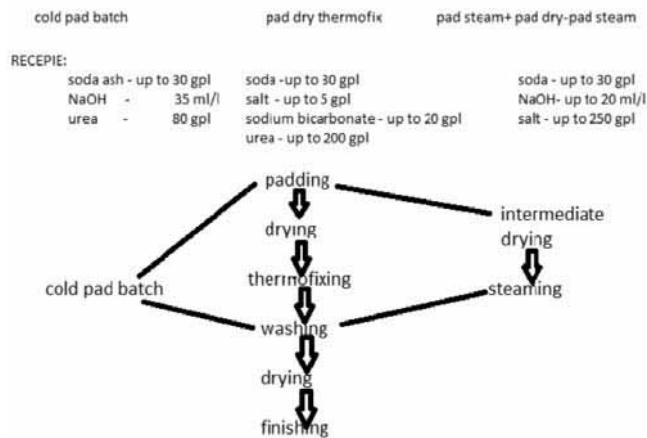

Fig 2.1: Process flow diagram with recipe for traditional dyeing process using reactive dyestuff

The first of these requires the smallest machine range, while other three requires more or less complex ranges[4].

Different process use different dyestuff depending upon their reactivity, because reactivity is reflected in:

- Duration of dwell time in the pad batch process.
- Temperature and time in pad dry thermofixing process
- Temperature and time in pad dry pad steam

DCT dyes require short time for fixation, hence can be fixed by the pad (with alkali)-batch sequence. Due to low reactivity, MCT dye requires a further backing for 3-5 minutes at 110-125° C or steaming for 3-4 minutes. Hence, MCT can be fixed by remaining three processes [5].

3. What made E-control's development necessary?

In order to bind the reactive dyestuff to the fibres, the dyestuff makers recommend a wide variety of ancillary substance and substance volume, depending upon the dyeing process employed. Sodium hydroxide, water, soda ash, urea and the salt are the chemicals which are used in large quantities. These chemicals when discharged exit partly with the exhaust air and most part contaminates the waste water during washing off.

Hence to avoid this pollution E-Control process has been developed.

To understand the background to E-control process and its success, it makes sense to start by looking at the situation in the textile finishing industry in recent years:

- The number of shades to be dyed has risen steadily.
- At the same time, textile finishers are expected to meet higher fastness specification.
- Environment regulations have become far more stringent in many parts of the world.
- Batch sizes have declined dramatically.
- Price pressure has risen enormously and delivery times are far shorter than in the past.

Dyeing process and products have to be adjusted to reflect these conditions. Productions personal also need to adapt. That was the trigger for the development of the E-control process [6].

4. E-control process

The E-control concept has been developed jointly by Monforts and Zeneca colours to provide a simple, rapid and economical continuous coloration process with minimum chemical usage. In this process, the reactivity of the dyestuff is exploited together with the drying behaviour of the fabric in such way that optimum colour yields can be achieved without the use of large and aggressive volumes of alkalis [7]. E-control is a combination of continuous batch process and a drying process.

The common recipe for use with the E-control process is shown as

- Dyestuff – X gpl
- Wetting agent – 1-2 gpl
- Sodium bicarbonate – 10 gpl

Here, apart from the dyestuffs, only 10 gpl sodium bicarbonate is used as ancillary substance. The urea, salt, sodium hydroxide solutions used in other dyeing processes are replaced in the E-control process by controlled steam content during drying[8].

4.1 The basic principle

The innovation utilises the physical law of water evaporation from cellulose to provide the optimum temperature and moisture condition within the hot flue drier, ideal for the efficient fixation of the selected dyes. E-control process comprises just three steps:

Padding → Drying → Washing off (shown in Fig 4.1)

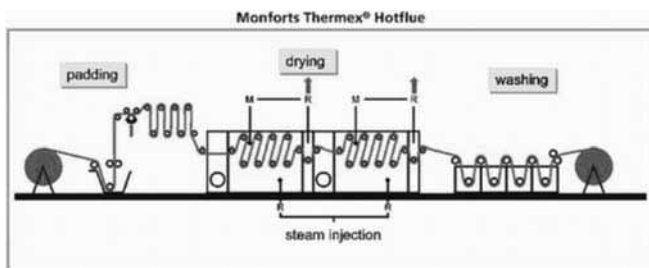

Fig 4.1: E-control reactive dyeing [9]

The complete fixation of the reactive dyes is not possible in normal drying conditions because of the wet bulb temperature, which is a characteristic of convection based drying systems. This indicates that during drying the temperature of the moist goods is far lower than the surrounding temperature. In normal drying processes, the temperature on goods can drop to 50-55° C. The exact temperature depends on the humidity of the air used to dry the goods. If humidity of the air is 25% and the air temperature is 120° C, the temperature on the moist goods is around 68° C. If humidity is 30%, the temperature on moist goods is around 71°C.

The three key variables – time, temperature, humidity are used to ensure accurate control of the drying process. Following Fig 4.2 shows a typical drying curve and the resultant temperature of the goods throughout the E-control dyeing process [6].

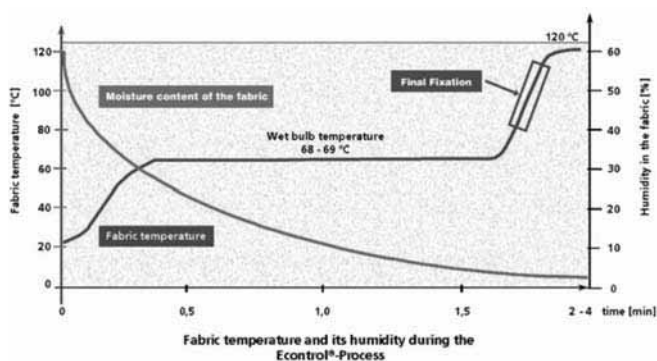

Fig 4.2 Fabric temperature and moisture content during the E-control process. [10]

The goods should spend about 2-3 minutes in the hot flue. However, it should be noted that these are average values, the actual drying time depends on the material to be dried. The E-control can be regarded as dyeing process with a liquor ratio of 1:0.7 in which dyeing time is 2 minutes [11].

4.2 Recommended dyes

The dyes used in E-control process have to be suitable for process conditions. Since dyeing is completed in approximate 2-3 minutes, the reactive dyes with high to medium reactivity are particularly suitable. All Levafix and most Remazol can be used. In practice, Levafix dyes are used for pale to medium shades, while Remazol dyes are used for medium to very deep shades. Dyes with double MCT anchors such as Procion H-EXL and Procion PX are not recommended for the E-control process.

4.3 Recommended alkalis and auxiliaries

Soda ash or soda ash/NaOH is normally used as alkali system. To ensure optimum reliability, it is essential to dose the alkali and dye solutions separately. Amount of alkali recommended for Levafix and Remazol are shown in Table 4.1 & Table 4.2 respectively.

| Amount of dye | Up to 10 gpl | >10-30 gpl | >30 gpl |
|---------------|--------------|------------|---------|
| Soda ash | 20 gpl | 20 gpl | 20gpl |
| NaOH 50% | - | 2ml/l | 4ml/l |

Table 4.1: Amount of alkali recommended for Levafix

| Amount of dye | Up to 20 gpl | >20-40 gpl | >40-60 gpl | >60-80 gpl | >80-100 gpl | >100 gpl |
|---------------|--------------|------------|------------|------------|-------------|----------------|
| Soda ash | 20 gpl | 20 gpl | 20 gpl | 20 gpl | 20 gpl | 20gpl |
| NaOH 50% | 3-5 ml/l | 6 ml/l | 8ml/l | 10 ml/l | 12 ml/l | 1ml/l 4ml/l |

Table 4.2: Amount of alkali recommended for Remazol

Common auxiliaries used in continuous dyeing process can be used, e.g. wetting agents, antimigrating agent and if necessary, sequestering agent. A mild oxidant can be added to prevent reduction of the dyes. Urea is not essential for the E-control process but upto 50 gpl may be advantageous in some circumstances [12].

4.4 Advantages

4.4.1 Advantage for the process

- Economical, even when dyeing small batches
- Rapid colour changes
- Simple to use
- Suitable for brilliant, very pale and very heavy shades
- Better washing-off properties, lower water consumption
- No reduction in light fastness as with the hot air fixing process
- Better colour yield than with the pad- batch process
- High reliability due to excellent reproducibility

- Environment friendly
- Short processing time.

E-control process contains 40% fewer variables, which means the possibility of making a mistake is reduced by 40%. That is only possible because the E-control process does not use a separate fixation step. By contrast, all other continuous dyeing process require repeat fixation of some sort.

4.4.2 Advantage in chemicals consumption

- No urea, no salt, less sodium hydroxide solution, no anti reduction chemicals
- Stability of liquor (approximate 8 hours)[13].

4.5 Product quality

No one would dream of running a racing car on low grade petrol and oil because they know they would have no chance of winning the race. The same applies to textile dyeing with E-control process. Good Product quality can only be fully achieved by using high quality dyes and chemicals.

4.6 Possible shades

E-control can be used to dye all shades that can be obtained with reactive dyes. These include brilliant turquoise, deep navy and black.

4.7 Fabric requirement

This process has been used for the fabric weights from 70 g/m² to 500 g/m². All cellulosic fabrics can be dyed, e.g. cotton, linen, viscous, tencel.

4.8 Energy requirement

E-control process needs far less energy than the PDPS process because it cuts out the extra fixation (steaming) [6].

4.9 Environment profile

The environment profile of industrial production process is becoming an increasingly important factor. It therefore has to be considered when selecting the optimum dyeing process. The key criteria are energy consumption, chemical requirement, effluent contamination and pollution of exhaust air. Considering above point, E-control is selected because it is a simple economical, efficient, energy saving and controlled process.

It also contributes significantly to environment pollution control. Avoidance is always the best solution as a contribution to reducing environment pollution. With

E-control high alkali, urea and salt consumption can be avoided as the process functions without these chemicals. Moreover, they do not have to wash out so they cannot contaminate effluent or exhaust air [6].

5. Limits

E-control has its limitations like Indanthrene dyes can be dried but not fixed as an air free steamer is required for these. Also, due to risk of frosting, it is not suitable for heavy weight pile and loop pile goods such as terry towelling [7].

6. Conclusion

The simple lab process and excellent reproducibility allow a quick response; rapid batch changes raise capacity utilisation, and lower energy costs and the reduced effluent loading supports sustainability.

Thus, E-control process is a simple, economical, efficient, environment compatible, ecological, energy-saving process. This process is an interesting alternative to the processes commonly used to date for dyeing of cellulose fibres using reactive dyestuff.

Acknowledgement

We are thankful to Prof. (Dr.) R. V. Adivarekar, Head of The Textile Department, ICT, Matunga, Mumbai for encouragement and guidance in writing this article

References

1. James Park, *Colourage*, November-2009, pp.39
2. S N Pandey, S N Chattopadhyay, N C Pan, A Day, *Indian Journal of Fibre & Textile Research*, Vol.19, March 1994, pp.34
3. Prakash D Pardeshi and Sujata G Manjrekar, *The Indian Textile Journal*, January-2003, pp.29-30
4. Dipl-Ing Kurt Van Wersch, *International Dyer*, January-1996, pp.28
5. Asim kumar Roy Choudhary, *Textile Preparation and Dyeing*, pp.549
6. Franz Peter Tolksdorf, *Colourage ITMA-ASIA*, 2005, pp.77-82
7. H.K. Rouette, *Encyclopedia of Textile Finishing*, pp.671
8. Dipl-Ing Kurt van wersch, *International Dyer*, January-1996, pp.29
9. www.adsaleata.com
10. www.adasaleata.com
11. Dipl-Ing Kurt Van Wersch, *International Dyer*, January-1996, pp.30
12. Franz Peter Tolksdorf, *Colourage ITMA-ASIA*, 2005, pp.79.
13. Dipl-Ing Kurt Van Wersch, *International Dyer*, January-1996, pp.31.



Compression Bandage Coated with Micro Encapsules of Herb *Ziziphus Jujuba* Extract

A. Shanmugavasan*

Department of Textile Technology, PSG College of Technology

T. Ramachandran

Karpagam Institute of Technology

Abstract

Compression bandage is made multi functional by coating micro encapsulated active plant extract on its surface which is an innovation. Compression therapy for treating lymphological and phlebological disorders uses compression bandage and its functionality is augmented with the coated microcapsules of oily stem extract of *Ziziphus jujuba* which is a herb used by the traditional practitioners for curing musculoskeletal disorders accompanied by massaging and fermentation. Aided by the sub-bandage pressure created by the compression bandage, the active molecules from the plant extract penetrate the skin and makes the bandage multifunctional and more effective in its curative ability. This is the postulation of this study. Surface coating and presence of microcapsules is confirmed by the microscopic analysis of the surface using scanning electron microscope. The coated bandage additionally displays antimicrobial activity against gram positive bacterium *Staphylococcus aureus* and therefore may resist microbial attack on the surface of the skin. FTIR studies indicate the presence of active functional groups in the extract. No significant change in the stretch of the fabric has been found after coating.

Key Words

Bi-functional, Compression Bandage, Medical Textiles, Microencapsulation, Musculoskeletal, *Ziziphus jujuba*

1. Introduction

Medical textile is one of the in focus areas in the field of technical textiles. Surgical bandages and wound dressings are classical examples of textiles used in the treatment of ailments. Bandages, as medical devices could be elastic as well as non-elastic. Developments in textile based dressings with self-healing property have been tried by coating them with several chemical and natural products thus making them take the functional role [1]. Compression therapy is used in treating phlebological and lymphological disorders such as varicose veins, leg ulcers, eczema and oedema [2] and other musculoskeletal disorders. The most common practice used by medical practitioners in the compression therapy is the usage of compression bandages. Based on the amount of compression required for the treatment, the stretch of the bandage is determined. Resting pressure applied on the affected part by bandage creates compression enabling the

venous pressure to be regulated. The blood flow in the vein is controlled and there by the disorder is managed. Use of compression bandages in the treatment of venous ulcers has been reviewed [3, 4]. Such bandages come under Class 1 medical devices. Compression bandages are classified based on four important aspects such as pressure, number of layers, components and elastic properties [5]. Elastic compression crepe bandages are termed “long stretch bandages” and the elasticity, as per DIN 61632 standards, is defined as the percentage elongation of the material following application of a force of 10 N/cm width of the bandage. The pressure developed beneath a compression bandage is governed by the tension in the fabric that is exerted when the bandage is applied. One way of creating fabric tension is by using the stretch yarns and the other method is by using textured and crimped inelastic yarns [6] and thus stretch of the bandage plays the major role in imparting pressure and is an indication of the ability of compression.

Bandages as substrate are also coated to enhance the amount of compression and also to widen their functionality. Zinc-Paste bandages, cohesive and

*Correspondance should be addressed to,

A. Shanmugavasan

Department of Textile Technology,

PSG College of Technology, Coimbatore-641004

Email : project.psgtech@gmail.com

adhesive bandages are examples for such bandages. Other than the coated compression bandages, there exist also medicated wound dressing. The coating could either be the synthetic chemicals, latex /rubber or medicinal products. The methods of coating are shear spreading, spray drying.

In the current study, an attempt has been made to coat compressive bandages with micro capsules of ethano pharmacologically proven herbal extracts. These bandages are expected to have both compression and herbal properties. Oily extract from the plant *Z. jujuba* has been selected for coating as it has been historically used in Indian traditional medicine. Such oils are applied with massaging on the affected parts. Stem bark of the plant contains alkaloids[7]. Cyclopeptide alkaloids, mauritine-A, mucronine-D, amphibine-H, nummularine-A and -B, jujabine-A and -B were isolated from the stem bark of *Z. jujuba* by Tschesche et al. [8] Tripathi et al. [9] isolated a new cyclopeptide alkaloid jubanin - C along with the known cycloalkaloids scutianine - C and zizyphine - A from the stem barks of *Z. jujuba*. *Z. jujuba* contains also sativanines of various classes [10]. Frangulofoline, another cyclopeptide alkaloid was isolated from the stem bark of *Z. jujuba* by Devi et al. [11]. Besides alkaloids, a pentacyclic triterpenoid, zizyberanolic acid has also been isolated from the stem barks of *Z. jujuba* [12], Lee et al. [13] isolated three more triterpene esters, 2-O-protocatechuoylaliphitollic acid, 2- α -hydroxypyraacrenic acid and 3-O-protocatechuoylceanothic acid from the root part of the plant. Due to the presence of such a wide range of phytochemicals, *Z. jujuba* has been used in the traditional medicine for a long time. The Cyclopeptide and peptide alkaloids from *Z. jujuba* were found to show sedative effects [14]. The traditional use of the stem barks of the plant for healing wounds is reported by Ullah et al. [15]. Massaging creates pressure which is equivalent to compression and helps the active substances from the extract to penetrate the epidermis of the human skin [16].

The bandages coated in this work will exert the necessary sub-bandage pressure similar to massaging and will aid in the penetration of the coated oily substance into the skin. The coated bandage fabric has been analyzed using FTIR spectroscopy for the functional groups and the distribution of microcapsules under a scanning electron microscope. The antibacterial property of the coated bandage has also tested.

2. Materials and Methods

2.1 Materials

A standard compression bandage fabric of 100 GSM in 8 cm width with mean extensibility conforming to the DIN 61632 standards is woven. The fabric is composed of 90% cotton, 9% polyamide and 1% polyurethane.

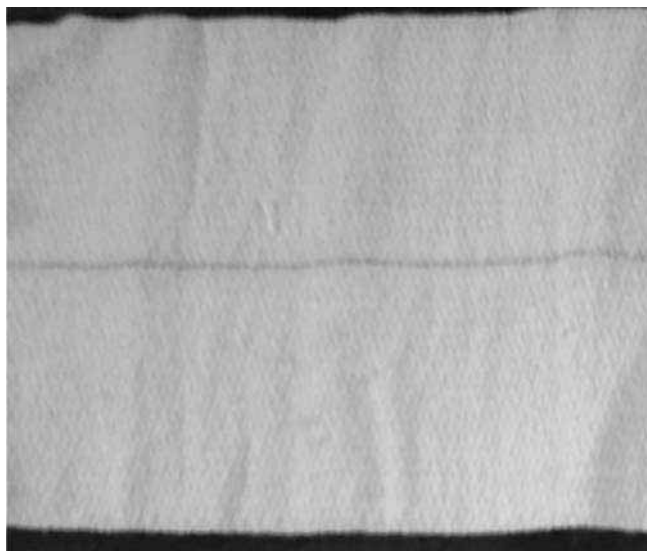

Fig. 2.1 : Selected compression bandage

The oily extract from *Z. jujuba* is collected from a traditional practitioner Indian medicine in Coimbatore. The extract is shown in Figure 2.2.



Fig. 2.2 : Oily extract from stem of *Z. jujuba*

2.1.1 Selection of preparatory method before coating

Various trials were done to coat the extract on the bandage fabric. Dip-dry, pad-dry-cure, spray-dry and brush coating methods were found unsuitable due to the high viscosity of the extract. Practical difficulties such as dissolution of the extract in a solvent, staining

on the skin and prolonged drying time, improper drying have also been faced. Retention of the active matter in the extract and the suitability for coating being the objectives, microencapsulation of the extract and subsequent coating has been identified as the best suited method for coating.

2.1.2 Microencapsulation (orifice – ionic gelation process)

The plant extract is used as the core material. Sodium alginate is taken as the wall material as it is a natural and commonly used wall material. Microcapsules containing plant extract are prepared by using 1% w/v low viscosity sodium alginate. Approximately 3% of sodium alginate solution is prepared. A quantity of 10 ml of oil is added to the polymer solution and mixed thoroughly to form smooth viscous dispersion by adding 10 ml of polysorbate 20, an emulsifying agent commercially available as Tween 20®. The oil-polymer mixture is sprayed into 0.5M 98% pure calcium chloride solution using “Pilot Type 64” model spray gun. The nozzle bore of the gun is 1.5 mm and it is designed to consume about 115-117 liters per minute at 2.10-2.80 kg/sq. cm. The spray gun is held vertically over the calcium chloride solution approximately 45-50 cm above the level. The droplets are retained in calcium chloride for 15 minutes for hardening of the capsules. The microcapsules are obtained by decantation in a centrifuge of make Remi R-8C and repeated washing with 99% pure isopropyl alcohol followed by drying at 45°C for 12 hours in a hot air oven. The microscopic image of the capsule is shown in Fig. 2.3.

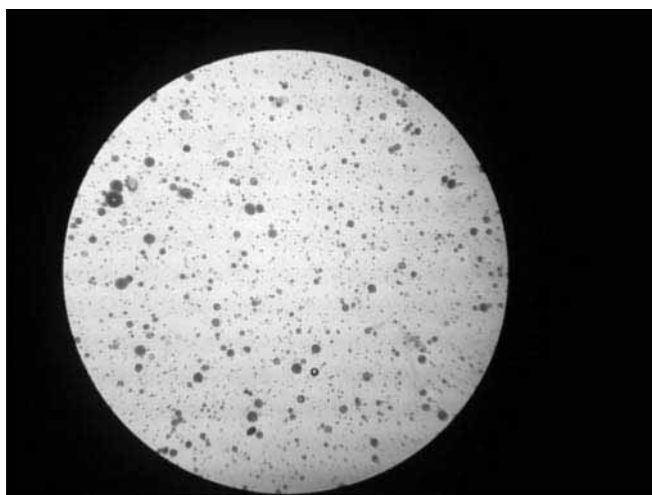

Fig. 2.3 Image of a microcapsule of oily extract

The residual wax quantity that the weft yarn acquired during weaving was removed by soaking the fabric in

boiling water bath for 20 minutes followed by squeezing and a 3-time wash in distilled water. The coating bath liquor is prepared by taking 10 ml of microcapsules in 30 ml of distilled water. 3.2g of citric acid is added to the bath as binder. The Material : Liquor ratio was kept at 1:20. The de waxed bandage fabric is immersed in the above bath at room temperature for 30 minutes. The fabric is dried at room temperature without squeezing for 48 hours. The control and coated bandage fabric is shown in Fig. 2.4.

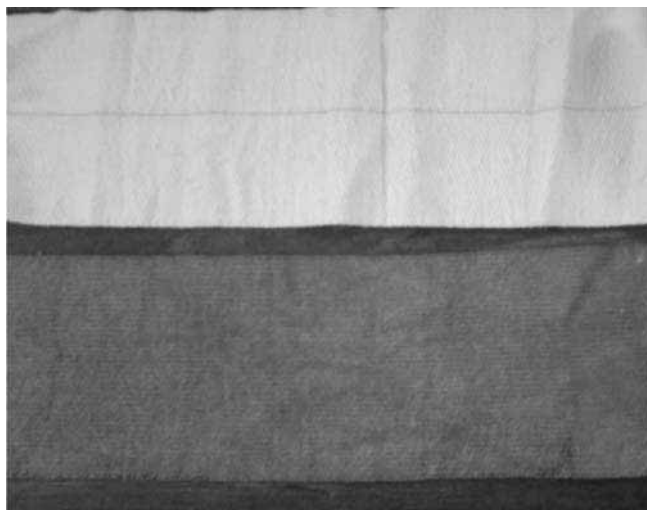

Fig. 2.4 Control and coated bandage fabric

2.2 Evaluation of the bandage

2.2.1 Increase of weight per unit area

The weight per unit area of the coated fabric is calculated by sampling a specimen of dimension 1” X 1” and weighing it on a Mitsubishi electronic balance. The percentage increase in the GSM after coating is directly proportional to the amount of extract coated on to the surface of the fabric. It is ensured that the add-on percentage does not inhibit the stretch of the bandage.

2.2.2 Bandage compression in terms of stretch

The bandage stretch before and after coating are measured as per DIN 61632 standard. The unstretched length (ul) of the bandage is noted down. The fabric is placed horizontally on a stretch table and 5 cm of each end is clamped. A force of 10N/cm is applied for a minute. The stretched length (sl) is measured. Bandage stretch is calculated using the following formula.

$$\text{Stretch \%} = \left(\frac{sl - ul}{ul} \right) \times 100$$

Statistical t-test is performed at 95% confidence level to check the significance in the change in stretch before and after coating.

2.2.3 Infrared Spectroscopy

The chemical functional groups present in coated fabrics are analyzed using Fourier transform infrared spectroscopy (FTIR). The spectrum is obtained using a Bruker instrument with ATR in the wave number region 400-4000 cm^{-1} .

2.2.4 Electron Microscopy

The distribution of the microcapsules of the extract on the bandage surface is examined using a scanning electron microscope at the magnification levels X1500 and X500.

2.2.5 Test for Antibacterial Activity

The antibacterial activity of the coated fabric is evaluated using agar diffusion method (AATCC100). Activity against a gram positive bacterium, *Staphylococcus aureus* and a gram negative bacterium, *Escherichia coli* is tested. Bandage application always being external on the skin the activity against the gram positive bacteria is more important.

3. Results And Discussion

3.1 Weight per unit area

The GSM of the coated fabric is calculated as 125 g/m^2 . The percentage increase in weight of the fabric per square meter is maintained at 4%.

3.2 Bandage compression in terms of stretch

The stretch of the bandage before and after coating was 106.8% and 106% on a mean of 10 test results. Statistical t-test analysis suggests no significant change in the bandage extensibility properties. The coating process is not affecting the bandage functionality significantly.

3.3 Infrared spectroscopy

The Fourier-transform infrared spectrum of the plant extract is shown in Fig. 3.1. The wave numbers

corresponding to various chemical functional groups have been analyzed as per Coates (2000) [17].

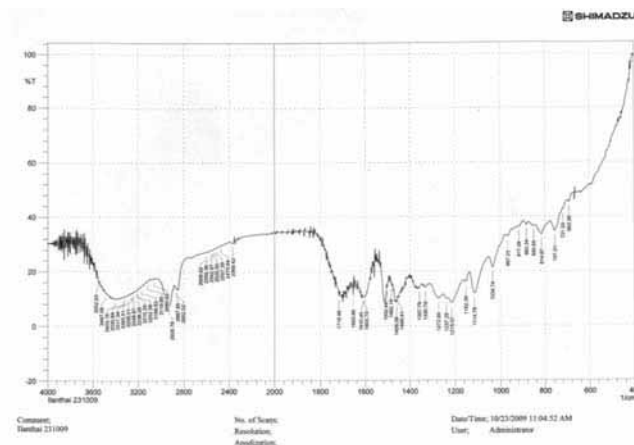

Fig. 3.1 : FTIR spectrum of oily extract of *Z. zujuba*

The FTIR spectrum shows a mixture of chemical compounds. The $-\text{OH}$ stretch in the range 3565-3692 cm^{-1} indicates the presence of phenolics. 3444-3692 cm^{-1} range shows the hydroxyl group $-\text{OH}$ stretch. The presence of phenolics is further justified by a distinct peak at 1462 cm^{-1} , corresponding to the $\text{C}=\text{C}-\text{C}$ stretch of the aromatic ring. The aryl $-\text{O}$ stretch of aromatic ethers (e.g. Methoxy phenols) is indicated by peaks at the wave numbers, 1272 cm^{-1} , 1236 cm^{-1} and 1215 cm^{-1} . Further evidences for the presence of aromatic groups are the in-plane C-H bending of the aromatic ring at 944 cm^{-1} and out-of-plane C-H bending in the range 851 cm^{-1} – 694 cm^{-1} . The corresponding C-H stretch of the ring is represented by the peak at 3069 cm^{-1} . Presence of carboxylic acids, acid esters, ketones and aldehydes is shown by the peaks in the range 1700 cm^{-1} – 1500 cm^{-1} . 1114 cm^{-1} is corresponding to the C-O.

3.4 Electron Microscopy

The scanning electron microscope image of the control sample and the oil coated bandage fabric at 1500X and 500X is shown in Fig. 3.2. The microcapsules are visible and the distribution appears to be random and the capsules are of varying size.

**SUBSCRIBE TO THE
JOURNAL OF THE TEXTILE ASSOCIATION**

Contact : taicnt@mtnl.net.in

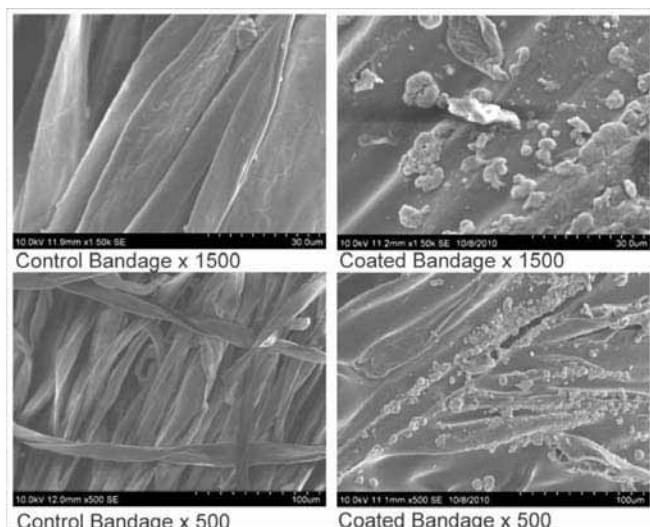

Fig.3.2 : SEM images of control and coated fabric at 1500X and 500X

3.5 Test for antibacterial activity

The coated bandage displays activity against *S.aureus* and the zone of inhibition is 24 mm. No activity has been found against *E. coli*. The zone of inhibition is shown in Figure 3.3. Activity against *S. aureus* is more important as it is the most widely present bacterium on the epidermis of the skin. Bandage being applied externally on the human body and it is in contact with the skin and its flora. The positive result against the gram positive bacterium, *S. aureus* is an advantage for the curative bandage. Gram negative *E. coli* is present mostly in intestine of human beings and thus activity against this bacteria is not vital for a bandage fabric.

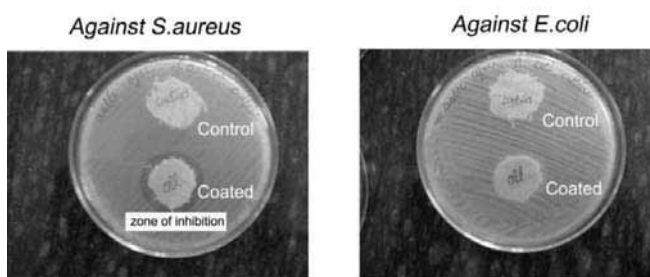

Fig. 3.3. Antibacterial activity of coated and control fabric sample against *S.aureus* and *E.coli*

4. Conclusions

Retaining the vital stretch property and thereby the basic functionality of compression of a compression crepe bandage, an additional functionality has been introduced. The concept of coating oily extract on a bandage fabric is innovative. Presence of the plant extract of *Z. jujuba* renders the bandage with bi-functional ability, as aided by the resting pressure active

ingredients from the extract may penetrate the skin and enhance the effectiveness of the treatment. The herbal extract imparts the bandage antibacterial activity against gram positive bacteria which is an added advantage. The coating does not hinder the stretch property of the bandage. The postulation that the active substances present in the extract, penetrate the human skin with the help of pressure created by the compression bandage has to be established. Suitable evaluation methods to establish the postulation is the future scope of this work.

References

- Gupta, B., Agarwal, R. and Alam, M. S., *Indian journal of textile & fibre research*. 35 (2010), 174-187.
- Bleckena, S. R., Villavicencio, J. L. and Kao, T. C., *J. of vascular surgery*, 42(6), (2005) 1150-1155.
- Cullum, A., Fletcher, A. and Semlyen, A., *Qual Health care*. 6, (1997) 226-231.
- Lee, A. J., Dale, J. J., Ruckley, C. V., Gibson, B., Prescott, R. J. and Brown, D., *Eur J vas endovasc surg*. 31 (2006) 542-552.
- Partsch, H., Clark, M., Mosti, G., Steinlechner, E., Schuren, J., Abel, M., Benigni, J. P., Coleridge-Smith, P., Cornu-Thènard, A., Flour, M., Hutchinson, J., Gamble, J., Issberner, K., Juenger, M., Moffatt, C., Neumann, H. A. M., Rabe, E., Uhl, J. F. and Zimmet, S., *Dermatol surg*. 34 (2008) 600-609.
- Cooper, A. S. Jr., Robinson, H. M., Reeves, W. A., Sloan, W. G., *Textile Res. J.* 35 (1965) 452-458.
- O.P.Pareek, Fruits for the future 2: Ber. International centre for underutilized crops, University of Southampton, (2001) Southampton, UK.
- R.Tschesche, I.Khokhar, H.Wilhelm and G.Eckhardt, *Phytochemistry*, 15 (1976) 541-542.
- M.Tripathi, M.B.Pandeya, R.N.Jhaa, V.B.Pandeya, P.N.Tripathi and J.P.Singh., *Fitoterapia*, 72(5) (2001) 507-510.
- N.H.Tan and J.Zhou, *Chem. Rev.* 106 (2006) 840-895.
- S.Devi, V.B.Pandey, J.P.Singh and A.H.Shah, *Phytochemistry*, 21(12) (1987) 3374-3375.
- A.B.Kundu, B.R.Barik, D.N.Mondal, A.K.Dey and A.Banerji, *Phytochemistry*. 28(11) (1989) 3155-3158.
- S.S.Lee, B.F.Lin and K.C.Liu, *Phytochemistry*. 43(4) (1996) 847-851.
- B.H.Han, M.H.Park and J.H.Park, *Pure & appl. Chem.* 61(3) (1989) 443-448.
- R.Ullah, Z.Hussain, Z.Iqbal, J.Hussain, F.U.Khan, N.Khan, Z.Muhammad, S.Ayaz, S.Ahmad, N.U.Rehman and I.Hussain, *J. Med. Pl. Res.*, 4(17) (2010) 1815-1821.
- Weerapong, P., Hume, P. A., Kolt, G. S., 2005, *Sports Med.*, 35(3) (2005) 235-256.
- Coates, J., *Encyclopedia of analytical chemistry*, John Wiles & Sons Ltd., Chichester; (2000) 10815-10837.

□ □ □

Shopping Behaviour of Teen Age Girls in Mumbai City

A. J. Shukla

Department of Textile and Apparel Designing,
S.V.T. College of Home Science, S.N.D.T. Women's University

Abstract

The retail industry per se has been present throughout history in India. However, it is only in the 1990's that retail in India witnessed so much dynamism and was considered as a sunrise sector. India also has a growing class of young customers who are aware and assertive about their shopping needs. Unless and until it is an emergency buy, most teenage girls feel shopping is no longer a matter of paying for what you want and leaving the shop. These twin developments are putting tremendous pressure on some of our existing traditional textile/ garment shopping areas. The neighborhood darzi and fabric stores are fast changing into boutiques and malls. This study focuses on the shopping behavior of teenage girls within the city of Mumbai and covers all income groups. The parameters-frequency of shopping, categories of garments and areas most frequented were studied.

The paper also presents an overview of some of the areas used consistently by teenage girls for their retail apparel shopping. The merits and demerits of traditional shopping areas against malls and boutiques were also compared and noted to prepare a map of some dense shopping areas.

Key words

Retail, Shopping, Global Retail Development Index (GRDI), Malls.

1. Introduction

1.1 Retail today

"There is only one boss- the customer and he can fire everybody in the company from the chairman on down simply by spending his money somewhere else"-Sam Walton.

Retail sales globally are driven generally by the people's ability to buy (disposable income) and the willingness to buy (consumer confidence)

Many people argue that the economic potential of BRIC countries- Brazil, Russia, India and China is such that they may become among the four most dominant economies by the year 2050.

Seen with the perspective of the Indian retail market, which has been among the fifth largest retail destination globally and ranked as the most attractive emerging market for investment in the retail sector by AT Kearney's 8th Annual Global Retail Development Index

**Correspondance should be addressed to,*

A. J. Shukla
Department of Textile and Apparel Designing,
S.V.T. College of Home Science, S.N.D.T. Women's University,
Sir Vithaldas Vidhya Vihar, Juhu Road, Santacruz (W),
Mumbai- 400049, India.
E-mail: armaitishukla@yahoo.com

(GRDI) in 2009. The apparel retail sector has tremendous scope for growth.

India also has 10 of the 30 fastest growing urban areas in the world and based on these trends it can be safely estimated that a million people will move to the cities by 2050.

1.2 The youth market

Today about 47% of India's population is under the age of 20 and will increase to 55% by 2015. This young population which is technology savvy, watches more than 50 TV Satellite channels and which displays the highest propensity to spend will immensely contribute to the growth of the retail sector in the country.

1.3 Mumbai City

The metropolitan city Mumbai has seen too many variations in retail players in an incredibly short time. Its urban apparel retail segment today is extremely fluid as well as volatile.

It is dominated by brands, multinational companies, advertisements and malls on one hand and the traditional apparel vendors in mom- n-pop stores, boutiques and roadside hawkers on the other.

Thus, the question is how do they satisfactorily cater to a varied segment of teenage girls from different income levels.

2. Research Strategy

The study focused on teenage girls within the city of Mumbai between the ages of 16-23 years covering a mixture of working as well as non-working participants from all income groups. The survey was conducted in geographical areas between Churchgate to Dahisar and Chatrapati Shivaji Terminus to Thane.

3. Methodology

The triangulation method of data collection was used. Quantitative as well as supportive qualitative data was collected by the closed end question survey method,(200 teenage girl consumers were interviewed to draw data from all areas). In-depth- structured interview schedules (40 subjects), and mapping of popular shopping areas was done.

4. Results and Discussions

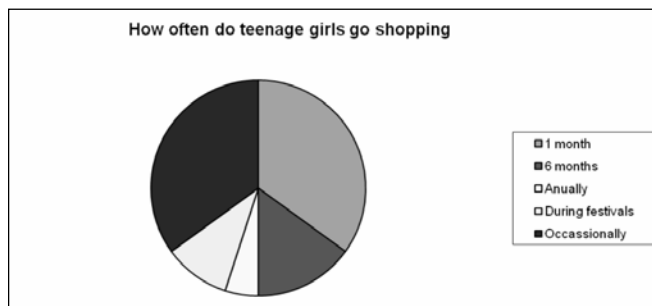

Fig.4.1. Regularity of shopping

4.1 Regularity of shopping

Mumbai's Retail boon is truly reflected in Figure 4.1. On an average 35% of the participants went shopping once a month and another 35% went shopping occasionally. For this section of subjects the In-depth interviews revealed that frequency of shopping varied depending on mood or need for clothing articles.

A meger 5% participants shopped annually and it coincided with the festive season. Festivals however do not seem to be the only time when shopping is done in Mumbai anymore, as only 10% of the participants went shopping only during festivals. For the others

festivals and special occasions motivated extra shopping sprees, both for the lower as well middle income groups.

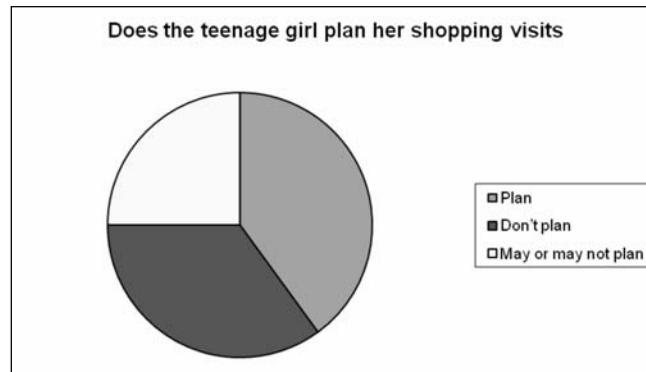

Fig.4.2 Planning of shopping visits.

4.2 Planning of shopping visits

Figure 4.2 shows that 40% of the participants planned their shopping visits and another 25% planned their visits for shopping articles with bigger budgets. The smaller articles and accessories were bought more spontaneously. However 35% of the participants were absolute spontaneous shoppers.

4.3 Budgets for shopping

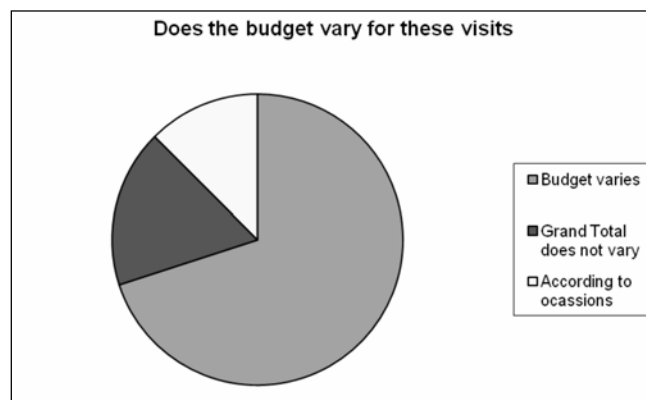

Fig. 4.3 Variations in shopping budgets'.

According to Figure 4.3; participants showing variations in their shopping budget were 70%. While a 17.5% said the money allotted to them for shopping was a fixed grand total. How they spent it on various articles was their choice. The frequency and budget involved in shopping also increased with participants who had either part-time or full time jobs (such as call center employees, tuitions, odd- jobs, summer jobs etc.)

VISIT US : www.textileassociationindia.org

4.4 Categories of garments and their frequency of shopping

The graph shown below is self explanatory.



Fig.4.4. Categories of Garments.

4.4.1 Western garments

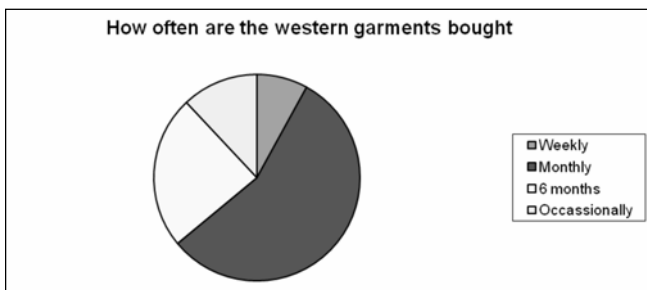

Fig.4.5. Frequency of buying Western Garments

Western garments are bought by teenage girls most often with T- Shirts being the favorite garment. Most girls felt that jeans could be bought occasionally but when coupled with a larger variety of T- shirts the complete wardrobe could be doubled. Results from the survey also pointed out that T-shirts within the price range of 50- 250 were most often picked up from popular shopping areas, smaller retail shops and malls.

4.4.2 Indian garments

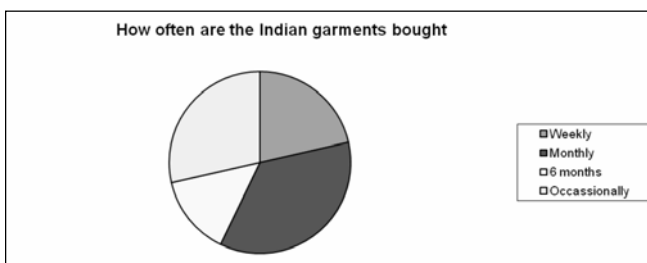

Fig.4.6. Frequency of buying Indian Garments

Indian garments on the whole were not bought as frequently as their western counterparts. The chief reasons observed in the survey were-

- Difficulty faced in mixing -n- matching the salwar, kameez or dupatta as they are normally bought as a set. This is in contrast to the more popular T-shirts which could be slipped on with any number of jeans. Short kurtas for Rs 100 were also therefore a favourite choice.
- Indian Garments according to several participants were bought specially for birthdays, festivals and special occasions where they were planned for and given a bigger budget.
- They also felt that stitching a salwar kameez was a more time consuming as well as expensive affair as compared to jeans, T-shirts, and skirts which once bought could be worn almost immediately.
- Need for an alteration was also mentioned as a reason for not regularly purchasing Indian garments. This causes delay in wearing a new garment.

4.4.3 Lingerie

Except for a single participant who bought lingerie once a month, most others bought them as and when the need arose. This seems to be a trend in all income and age groups.

Reasons for the same were

- Why spend good money on lingerie as it is hardly seen.
- Their mother usually picks it for them.
- It's embarrassing to go to the shop so often with specific requests for colors, styles etc.

These general answers indicate the lack of importance teenage girls give to their personal needs and choice of lingerie. (The matter could need more probing).

Given below are maps that can create a ready reckoner for young girls shopping in Mumbai. The maps display



the density of shopping areas throughout Mumbai. They also show the relation of garments bought to the areas preferred by the teenage girl for her specific shopping needs. The garments selected were- Jeans, T-shirts, skirts, salwar kameez and lingerie

5. Conclusion

In today's fast paced world, the teenage girl is spending more than ever to acquire comforts that were beyond her reach just a few years ago. Growing fashion consciousness and high expendable incomes coupled with a boom in the retail sector is a setting stage for a rapid growth in both private labels and the huge un-organized or unbranded sector.

However in the Indian scenario, from our study it was apparent that these teenagers as consumers are value seekers who also want diversity. Product purchasing today commands a variety of decision factors as compared to yester year's mono obsessive product and price priority. The average teenager looks out for certain specific parameters like quality, contemporary trend along with correct pricing. She wishes to be fashionably dressed, and thus appreciates if a garment is tailored to meet her individual needs and desires or alters them accordingly.

When it comes to considering the size of the Indian retail market and its extremely bright future prospects, brands are bound to face the heat of competition. As the situation presents itself today, through the survey we find that the teenage girl has a vast spectrum to choose from. We see the humongous un-branded segment that operates low cost and supplies to stores,

street fashion vendors and smaller regional outlets are in more demand than the premium segment who have high performance parameters. Today's value seeking teenage girl usually opts for "JEANS" from branded outlets to provide her a solid basic garment, along with low cost varied range of T- shirts to add variety the "ZING" in her wardrobe. But for buying traditional garments she frequently requires planning and companionship.

Thus today although shopping frequency has improved many of Mumbai's teenage girls are turning into demanding customers who cannot be ignored in this selling frenzy.

Acknowledgement

The author is thankful to PUKAR (Partners for Urban Knowledge and Acton Research) and Ratan Tata Trust for sponsoring the project under the Youth Fellowship Programme.

References

1. Kotler, Philip., "Marketing Management", 11th ed., Pearson Education, Inc., India (2008).
2. Gini, Stephen Frings., "Fashion from Concept to Consumer", 3rd ed., Prentice- Hall Inc., USA(1999).
3. Leslie, D.B., " The Business of Fashion", 3rd ed., Fairchild Publications, Inc., USA(2002).
4. Gibson, G. V., "Retail Management- functional principles and practices", 3rd ed., JAICO Publishing House, India (2008).
5. Swapna P., " Retailing Management- Text and Cases", 3rd ed., Tata Mc Graw- Hill Publishing Company Limited, India (2009).

□ □ □

9th INDIA INTERNATIONAL TEXTILE MACHINERY EXHIBITION

INDIA-ITME 2012

Dec. 02nd to 07th, 2012

Bombay Convention & Exhibition Centre, Goregaon (E),
Mumbai – 400 065 (India)



Ms Shraddha Teli , a grand award winner while representing India, at International Science and Engineering Fair held at USA, has a Patent as well as CSIR Golden Jubilee award and over 50 certificates and honours to her credit. With brilliant academic career in Science she graduated in Business Management Studies from Mumbai University with First Class Distinction and subsequently worked abroad for 2.5 years. Presently she is serving in Rossari Biotech in Marketing Department.

Significance of Corporate Social Responsibility in the Trade of Retail Branded Apparels

Shraddha M. Teli

Business Management Studies, Podar College of Commerce & Economics

Abstract

Corporate Social Responsibility is becoming buzz word in today's business. Every serious player in the business does require CSR programme to enhance its image and brand value of the company. The conscious customer does demand not only quality apparels, but also wants to encourage the philanthropic and socially responsible practices on the part of garment manufacturers and suppliers. How far the commitment of such manufacturers to good ethical practices and to the society and welfare of work force as well as respect to environment protection influence the decision of the customer to buy the goods from such suppliers is the core aspect of this study. The results based on the market survey do reveal that the customer is ready to spend a little more money for encouraging such positive attitude in suppliers. There is distinct inclination among the customers to prefer such suppliers who follow CSR. These good practices do have influence in establishing lasting links between customer and branded garment suppliers and it enhances the good will and loyalty among the customers.

Introduction

The latest census indicates that we Indians are 1.21 billion who cannot be ignored in this free market economy. And thus it makes business sense to concentrate on Indian market which is about to swell as the economy is growing. No one can forget the visit of the American President Barack Obama to India early in 2010, who also looked at India as a market for the defense deal, which had tremendous potential of creating new job opportunities back home in U.S.A. to pump in resurgence in the recession riddled American economy. India's growing importance in the world economy is convincing a number of developed countries, about her legitimate right to become the permanent member of the Security Council of the United Nations.

In this new millennium when the world trade is globalised and has become seamless, while the opportunities of business at our door steps are enormously swelled, the ways in which our new business transactions have to be run have undergone radical changes. Gone are the days when the balance sheet and the profitability of a Company were considered the indicators of a successful venture. In

the modern world, unbridled industrialization and profit maximization have created havoc and posed a tremendous risk in the sustainability of the planet. For example, the alarming rise in the global warming is a result of irresponsible neglect of the environment, during the intoxicated spirit of profiteering at any cost. Similarly, although the number of billionaires has been on a rise in the Forbes List, the disparity between the rich and the poor, developed and developing, has been widening at a galloping rate. The social compliance and accountability, are also not given the due attention, and hence the so-called prosperity of a venture or a nation is required to be examined under the backdrop of its ability and agility to respond to the needs of the society along with creating a spirit of happiness, among the inhabitants. The human development index (HDI) which is also under the scanner to see whether the parameters used are truly reflective of the societal development. Hence the human happiness index (HHI) is also being advocated, because in the final analysis it is the happiness of the individual or the family which counts rather than their income generating power or wealth, although the latter ones are important. When the family is happy, individuals productivity is raise

and thus one needs to see what makes us happy rather than simply the growth of per capita income. It could be very simplistically stated ,that when India won World Cup in cricket, over one billion people considered it as their own victory and it made them happy and surely the effect of it could be seen, as psychologist put it, in the increased productivity. In other words, financial bottom line of business is fine for its success, but one should never forget for sustainable progress the business has to be run with environmental consciousness as well as with social responsibility. When these two other bottom lines are taken care of, the work force is happier and positive and motivated. The environment is preserved and respected and final analysis it adds to the vitality for sustenance of the business.

Triple Bottom Line

Corporate social responsibility is often likened to a three-legged stool. The three legs are people, planet, and profit, and each leg depends on the other two. The stool collapses if all three factors are not balanced.

1. **People** - Social sustainability (employees and communities)
2. **Planet** - Environmental sustainability
3. **Profit** - Economic sustainability

The success of any business venture in this modern era is measured in terms of the progress the company makes in these three dimensions which are quite important for the sustainability of the firm. Earlier the progress used to be governed and scaled in terms of the profits companies made. However, the investors look at sustainability of such firms and for the same, it becomes imperative for them to examine as to what extent the company takes care of its stake holders and the society at large in addition to the protection of the environment in which it is established. When such a balanced

approach is adopted, the success becomes meaningful. CSR certifications thus take into account this triple bottom line of the business as shown in Chart 1.

Purpose of Business

Why do businesses exist? What is the purpose of a business, or, in the bigger picture, what is the purpose of any Economic system, say a Company?

The derivation of the word Company comes from the two Latin words, *cum* and *panis*, which mean “breaking bread together”[1].

How does this origin translate in today’s business environment? What are or what should be the goals of the modern corporation?

I think many people assume, wrongly, that a company exists simply to make money. While this is an important result of a company’s existence, we have to go deeper and find the real reasons for our being. As we investigate this, we inevitably come to the conclusion that a group of people get together and exist as an institution that we call a company so that they are able to accomplish something collectively that they could not accomplish separately – they make a contribution to society, a phrase which sounds trite but is fundamental.

- Dave Packard²

Co-founder of Hewlett Packard Company in 1939

Hence, Corporate Social Responsibility (CSR) represents an attempt to address these questions.

The World Business Council for Sustainable Development in its publication “*Making Good Business Sense*” by Lord Holme and Richard Watts, used the following definition.

“Corporate Social Responsibility is the continuing commitment by business to behave ethically and contribute to economic development while improving the quality of life of the workforce and their families as well as of the local community and society at large”

The World Business Council for Sustainable Development has described CSR as the business contribution to sustainable economic development. Building on a base of compliance with legislation and regulations, CSR typically includes “beyond law” commitments and activities pertaining to:

- corporate governance and ethics
- health and safety

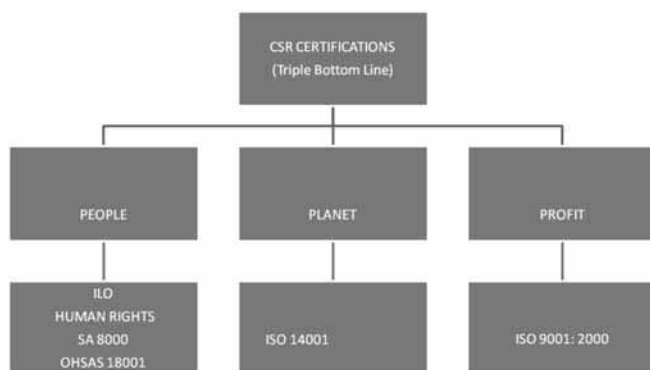

Chart 1.Certifications involved in CSR

- environmental stewardship
- human rights (including core labour rights)
- human resource management
- community involvement, development and investment
- involvement of and respect for Aboriginal peoples
- corporate philanthropy and employee volunteering
- customer satisfaction and adherence to principles of fair competition
- anti-bribery and anti-corruption measures
- accountability, transparency and performance reporting
- supplier relations, for both domestic and international supply chains.

These elements of CSR are frequently interconnected and interdependent, and apply to firms wherever they operate.

In this new “ethical market place” the overall performance of the companies is being judged by their customers, investors and employees not only in terms of prosperity of figures in their balance sheet but also on corporate morality and ethical standards being practiced by them.

51% of India’s population is under 25 years of age and about 60% of the total Indians belonging to the category of consuming class. The strong middle class with good purchasing power is expected to touch 500 million by 2015 and as we know, purchasing of garments is the first thing in a person’s life happens when his or her income generating power enhances. The overall textile and apparel trade is thus a reflection of India’s growing prosperity. This trade presently is about US\$ 45 billion dollars and is expected to grow to US\$95 billion dollars within a few years and about US\$ 50 billion of it is likely to be the export share. In this over all trade, the share of apparels is going to increase to 70% and quite a lot of the same will constitute “the branded apparel sector”, as the customers are not only becoming quality conscious, but also of their social status and modern apparels are used by them as an expression of their personality.

Today’s consumer whether living in India or abroad, is dictating terms with respect to the performance of properties and quality of the apparels he wishes to buy. Hence, not only does he expect good wrinkle resistance and color fastness of the garments he chooses, but also wishes to ensure that such products are manufactured

without exploiting the vulnerable class of society (like child labour) or disregarding environment protection norms. The international supply chain brands like Walmart, GAP, etc. go for the garment suppliers having the certification such as SA 8000, OHSAS 18001, ISO 14001 and ISO 9001, which are indicative of the commitment of these companies to corporate social responsibility.

Market Survey judging the response of the Customers

The present paper is based on the survey of the modern customers as to what he or she thinks when buying the branded apparels. A questionnaire was thus formulated to understand the customer’s perspective on CSR. The sample base included the enlightened and educated individuals such as professionals from different companies and senior college and university students who make a lot of purchase and are brand conscious. They were from Mumbai, Delhi and Chandigarh and their age group varied from 20 to 40 years. The questionnaire which they filled and their cumulative responses are summarized as follows:

*Cumulative responses of 75 Respondents (Nos. in the tables indicate the Distribution of Respondents with respect to specific question)
(0-25% agreement is like O.K., 25-50% fairly good ,50-75% is very good and 75-100% excellent or very strong)*

1. Your Selection of a branded apparel depends on the following parameters

| Level of Agreement (%) | (0-25) | (26-50) | (51-75) | (76-100) |
|---|--------|---------|---------|----------|
| Purely on Cost basis | 18 | 21 | 25 | 11 |
| Variety of choices for selection | 3 | 10 | 30 | 32 |
| Ambience of the retail outlet | 13 | 17 | 37 | 8 |
| Customer service offered at the outlet | 7 | 27 | 21 | 20 |
| Brand image of the product | 6 | 18 | 25 | 26 |
| Socially committed business house offering the product | 20 | 25 | 26 | 4 |
| Ethical practices followed by the Company | 17 | 20 | 25 | 13 |
| Discounts / free gifts on the purchase offered | 9 | 24 | 24 | 18 |
| Part of the purchase cost as a contribution to philanthropic causes | 21 | 23 | 25 | 6 |
| Past satisfying experience in the use of the Company’s apparels | 1 | 11 | 24 | 39 |

2. **If the background of the Company is known to you, will your buying decision be influenced by the Company's commitment to CSR ?**

58 = Yes 17 = No

3. **In your opinion, which of the following application areas of CSR interest you?**

| Level of Agreement (%) | (0-25) | (26-50) | (51-75) | (76-100) |
|---|--------|---------|---------|----------|
| Corporate governance and ethics | 10 | 20 | 24 | 21 |
| Commitment to: Health & Safety of workforce | 5 | 19 | 23 | 28 |
| Environment Stewardship | 3 | 19 | 27 | 26 |
| Human rights | 6 | 13 | 27 | 26 |
| Corporate Philanthropy | 9 | 27 | 22 | 17 |
| Underprivileged people | 6 | 18 | 32 | 19 |
| Anti - Corruption measures | 5 | 11 | 24 | 35 |
| Adherence to fair competition | 8 | 20 | 25 | 22 |
| Social Accountability | 6 | 20 | 31 | 18 |
| Transparency in Working | 4 | 14 | 33 | 24 |
| Performance reporting | 6 | 20 | 28 | 21 |
| Community development | 6 | 17 | 28 | 24 |
| Supplier relations | 6 | 23 | 26 | 20 |

4. **According to you, does commitment to CSR enhance the image of the Company?**

67 = Yes 8 = No

5. **Do you agree that in a situation where all the other parameters influencing your buying decision of apparel remaining fixed, CSR will be the propelling force to make the selection?**

43 = Yes 32 = No

6. **Will you choose to encourage a CSR driven company by opting for its products even if they are at a slightly higher cost (all factors remaining constant)?**

56 = Yes No = 19

7. **Will your choice of branded apparel be hampered if you came to know that the Company is engaged in child labor exploitation?**

59 = Yes No = 16

8. **Will you continue to be a loyal consumer of an apparel brand marketed by a company involved in tax evasion & corrupt practices?**

11 = Yes No = 64

9. **Does the intensity in the scale of CSR operations and the nature of CSR activities among the two CSR driven companies marketing branded apparels, swing your buying decision?**

32 = Yes No = 53

10. **In your perception, what % of Sales and Brand Image is enhanced due to the commitment of**

the Company to CSR activities?

29.4 % of Sales 56.6 % of Brand Image

After the cumulative responses were gathered, the next step was to analyze it dispassionately and peep into the hearts of the consumers as to what do they feel about CSR as a whole and application of the same by retailers. To what extent their decisions are influenced as mentioned earlier.

Summary of Results

The survey of young customers of branded apparels, clearly brought out the following facts

- Indeed cost is the prime factor, but it is not the only one and there are other parameters upon which buyers decision is dependent when branded apparel from Retailer is to be bought.
 - The other parameters include availability of variety of Choices for Selection.
 - Ambience of the Retail Outlet.
 - Customer Service offered at the outlet.
 - Brand Image of the product which very strongly influences their decision.
- If business house offering the product is Socially committed. In fact 95 % respondents felt strongly that CSR does influence their buying decision.
- Ethical Practices followed by the Company: Around 77% of the respondents are in the agreement with it which indicates that there exists strong soft corner in the hearts of buyers for the retailers' commitment to ethical practices.
- Discounts and Free Gifts on the purchase offered, do influence their decision and they were quite frank about it, but it is one of the many parameters initiating them towards buying the apparels.
- If they know that the part of the Purchase cost is going to be a contribution to philanthropic causes, they are positively influenced by it and around 72% said so.
- Past Satisfying Experience in the use of the Company's apparels also attracts them again and again. In other words delighted customer comes back to the stores and Customer Satisfaction is the key factor.
- If the background of the Company is known, majority of them would like to prefer retailer committed to CSR for their purchase.

Following application areas of CSR interest them strongly or significantly.

- Commitment to -Corporate Governance & Ethics (87%)
- Commitment to – Health & Safety (93%)
- Commitment to – Environment Stewardship (96%)
- Commitment to – Human Rights (92%).
- Commitment to – Corporate Philanthropy (52%).
- Commitment to – Underprivileged people (82).
- Commitment to – Anti- Corruption Measures (87%).
- Commitment to – Adherence to fair Competition (89%).
- Commitment to – Social accountability.(92%).
- Commitment to – Transparency in Working (95%).
- Commitment to – Performance Reporting (92%).
- Commitment to – Community Development (92%).
- Commitment to – Supplier Relations (92%).
- Majority agree that image of the company is enhanced due to its commitment to CSR .
- Quite a significant majority, 57% feel CSR is driving force for their decision provided other things remain fixed such as cost, quality, variety etc.
- It is heartening to note that 75% are ready to pay slightly higher cost and encourage CSR commitment of the retailer.
- A very clear message is given by 79% of the respondents that they are not going to deal with retailers involved in Child labour.
- Customers have their own ethical values to preserve and thus 85% said that they will stop their dealing with the retailers involved in tax evasion & corrupt practices.
- The customers do not wish to go into those details of CSR activities minutely. However, suffice is for them as long as the Company is CSR policy driven.
- It is heartening to note that almost all the respondents felt that, there will be positive influence of CSR activities of the retailers on their Sales and Brand image. Average increase in the sales due to CSR activities has been predicted to be 29.44%.
- Similarly average enhancement in the Brand Image is predicted to be around 56.61%.

All this strongly substantiates the fact that CSR is a key factor which can significantly enhance the Brand Image of the company and thus result in boosting the sale of the branded apparels.

However, does CSR need to be limited to Codes of Conduct? The obvious answer is no. Codes of conduct with respect to child labour, human rights, workers rights, ethical practices etc prescribe bare minimum standards on working conditions and compensation. I feel CSR should not be limited to only improving the compliance level to social, environmental and financial bottom lines only. The companies need to think beyond such perspectives, and realize that they carry an obligation to the society in which they are established. And to make it happen or instill in them such a motivation, money or mere lifeless technological implements will not be just sufficient. Beyond all these resources, which are definitely quite relevant, there has to be a purity of motive and true love for humanity. The transformation of individuals in authority, is required into such spirited souls that they are always charged with overwhelming desire to serve the society come what may. And at that point CSR activities will become a blessing in disguise for all the recipients.

The Way Forward

At the end I propose some of the measures that the Indian fashion and apparel industry can undertake as the part of their CSR programmes:

1. Adopt human rights perspective and transparent governance based on justice and fairness which may help companies to visualize themselves as private institutions for public good.
2. Support NGOs working with underprivileged people by using their products such as stationery, gift items, packaging material, greeting cards etc.
3. Improve working conditions in factories/ workshops in terms of general upkeep and also health and safety of the workers.
4. Take a decision to make a small beginning on CSR by identifying a social cause or two that is dear to your heart and is important for the community where your business operates, and evaluate how you can contribute.
5. Make shopping disable-friendly for about over 6 per cent of the Indian population is disabled. These people need to shop for themselves and for their dear ones.
6. Encourage home-based enterprises/workers who are involved in embellishments of apparels .Not only they look after their children and elderly people, but also support their family monetarily.
7. Encourage products emanating from traditional crafts and/or cultural heritage such as hand

embroideries used on fashion products. The benefit of such an exercise should reach the craftsman instead of the middlemen.

8. Undertake projects aimed at capacity building and market linkage of craft clusters/groups which can help them to take care of themselves.
9. In addition companies can support the community through a number of activities that use both its staff and resources. This could include making charitable donations, allowing staff to volunteer their skills to help community groups, or donating PCs and office equipment to organizations that need them etc.

That era is not far off when companies will be adjudged on the basis of their ethical Index along with their share price on Sensex. And to achieve the altitude in ethical index it's important that we take steps in changing our attitude of looking at CSR.

To move on this path there is a dire need to create awareness to develop a more coherent and ethically-driven discourse on corporate social responsibility. CSR is still sometimes seen as "green wash" to clean the sins of pollution, or "white wash" to provide a facelift to the company's public image. But we must believe that, in fact CSR offers stimulating innovative business and technological initiatives for touching new market zones on one hand, and on the other hand, it gives a cleaner societal reputation and socially responsible identity to companies, involving the companies and their employees in the long-term process of positive social transition.

References

1. Michael Arndt, *Business Week*, March 24, 2003, pp22-23
2. Charles Handy, 'What's a Business For?' *Harvard Business Review*, December 2002, pp54.



K P RINGS

ALWAYS BEST & ECONOMICAL
SINCE 1973

Rs. 36/-



Our rings are manufactured on CNC Machines of LMW



For Standard
Blackodised finish
Rings of 38 - 55mm Dia
Equivalent to
LMW Black Pearl rings
(Suitable Upto 17000 rpm.)

MANUFACTURED
AS PER
ISO
STANDARDS



Profile of our rings are checked on 50 x profile projector to avoid slightest deviation

KOTHARI TEXTILE INDUSTRIES

23/24 JINTAN UDHYOGNAGAR, SURENDRANAGAR - 363002, GUJARAT. PH: 91-2752-220020 FAX: 91-2752-230643
 CELL: 91-9825310201 / 9825310203 e-MAIL: kotharitextile@rediffmail.com Web: www.kptextilerings.20m.com



Arvind Sinha is B.Tech from Bhiwani and MMS from Bombay University. He has been involved with various industries in India and abroad for last thirty years. Although he is a hard core textile man but diversified in various fields such as Foods, Financial Services, implementation of Food Safety Management Systems and Art and Antique valuation. He has been very actively involved with World Bank and IMF for last many years for various projects and received Appreciation Certificate from World Bank and IMF for his outstanding contribution for various studies. He is currently Chief Advisor and CEO of Business Advisors Group which is a leading sourcing company for Relief Supplies globally and also the content creator and provider for critical studies and management issues. His study on human rights in jails is widely appreciated and heading for a Doctorate consideration by leading UK Management Institute. He has presented more than 150 papers so far in various leading conferences all over the world and more than 11 subjects including Art History, Defense Forces, Critical Management, Disaster Management, effective Relief supplies etc. He also deals in Camouflage Fabrics and is very actively involved in developing, designing and procuring Camouflage Fabrics in big volumes.

He is an Art and Antique collector and three of his records are listed in India Books of Records, Asia Books of Records and Limca Books of Records and heading for listing in Guinness Books of World Record.

Textiles volumes are shifting South-East Asia

Arvind Sinha

CEO & Chief Advisor, Business Advisors Group

Rising costs in China are sending more buyers to South-East Asia

"Fashion is a form of ugliness so intolerable that we have to alter it every six months." Oscar Wilde's quip now sounds hopelessly out of date. Fashions change far more often than twice a year. And the rage trade is as footloose as its customers are fickle. It goes wherever clothes can be made cheaply and reliably. Until recently, that meant China. But as Chinese wages soar, buyers are looking elsewhere. South-East Asia could be the next big thing.

China still dominates the business. It supplies nearly half of the European Union's garment imports and 41% of America's. But more orders are shifting to lower-wage economies such as Cambodia and Vietnam, where garment factories are mushrooming. Vietnam is already the second-largest supplier of clothes to America.

The new tigers are still cubs. They often have to import fabrics from China to stitch into clothes, so their transport costs are high. For buyers in a hurry, it is hard to beat China's mix of scale, speed and flexibility; Suppliers in South-East Asia are all clearly behind. There are capacity issues and also volume of scales not available, therefore it is very difficult to ignore China. Over a period of time last many years very huge capacities are built in China.

One way to catch up would be to knit together textile and garment producers in the Association of Southeast Asian Nations (ASEAN) to create a regional supply chain. Vietnam does not produce denim, but Indonesia does, and its denim can be exported tariff free within ASEAN to sew into jeans. This sort of partnership, promoted by USAID, America's aid agency, is attractive to fashion buyers who prefer an integrated, one stop service. It is also a step towards the single market that ASEAN is supposed to turn into by 2015.

The idea has been knocking around for a while, but has been given a jolt by China's rising wages. Since mid - 2010 the price of American garment imports has risen by around 10%, partly because of high cotton and oil prices but also because of Chinese wage inflation.

Last year leading American fashion retailer, vowed to cut the share of Asian goods it sourced from China from half to one third, within 18 months. Other global brands are following suit. Every company is serious about it and considering alternative source of supplies than China, ultimately reducing the dependence on China.

ASEAN manufacturers are forming alliances. For example, owners of textile mills in Bangkok, ships his pre-dyed fabrics by road to neighboring Cambodia,

where another factory cuts and sews them into summer blouses for Benetton, an Italian brand.

To compete with China, ASEAN needs to make it easier to move goods around. New roads and railways, plus faster customs clearance, all help. But infrastructure bottlenecks can delay shipments. This is a no-no situation for fast fashion. Winter frocks delivered during the spring are worthless. Timely delivery is the only success formula for fashion.

China still has plenty of cheap labour in northern and inland cities, far from the overheated coastal boomtowns. But as it grows richer, wages will rise in the hinterland, too. Its factories will continue to churn out clothes, but they will increasingly shun simple items, such as polo shirts.

Even Chinese firms are starting to outsource low end clothes manufacturing to Vietnam and Cambodia, and India. India can also be a major alternative but in India there is a volume problem and composite manufacturer who have all facilities under their control are very few. Therefore shipment delays are possible from India.

Hence the ASEAN situations are heading for change where the capacities will be distributed at various locations at various countries.

Sourced and Compiled by
 Mr. Arvind Sinha
 CEO & Chief Advisor
 M/s. Business Advisors Group
 Cell : 09820062612
 Email : arpsinha09@gmail.com



Announcing...



67th All India Textile Conference

Hosted by

THE TEXTILE ASSOCIATION (INDIA) – Delhi Unit

4th & 5th February 2012

Theme:

“Textile & Clothing – Emerging Global Scenario”

Venue: Habitat World, India Habitat Centre, Lodhi Road, New Delhi, India

Branding opportunities available through Conference Partnership plans, Advertisements in conference souvenir & Delegate Registration

Contact:

Mr. Ashok Juneja – Conference Chairman - +91 9891593332

Mr. R. Dudeja – Conference Secretary - +91 9811730846

E-mail: 67aitc@tai-delhi.org, Website: www.tai-delhi.org



Carbon Footprint in Textiles



The term carbon footprint is commonly used to describe the total amount of CO₂ and other greenhouse gas (GHG) emissions for which an individual or organization is responsible. Footprints can also be calculated for events or products. The full footprint of an organization encompasses a wide range of emissions sources from direct use of fuels to indirect impacts such as employee travel or emissions from other organizations up and down the supply chain. When calculating an organization's footprint it is important to try and quantify as full a range of emissions sources as possible in order to provide a complete picture of the organization's impact.

A carbon footprint is a measure of the severity of the impact our activities have on the environment and particularly on the climate change. It measures the impact by the amount of greenhouse emissions, produced through the burning of fossil for electricity, heating etc in our every day lives. Activities that have a large carbon footprint produce large amounts of greenhouse gases and therefore have a large impact on the environment.

Types of Carbon Footprints

In this figure the boundaries have been made which tells the role of various participants in carbon footprint.

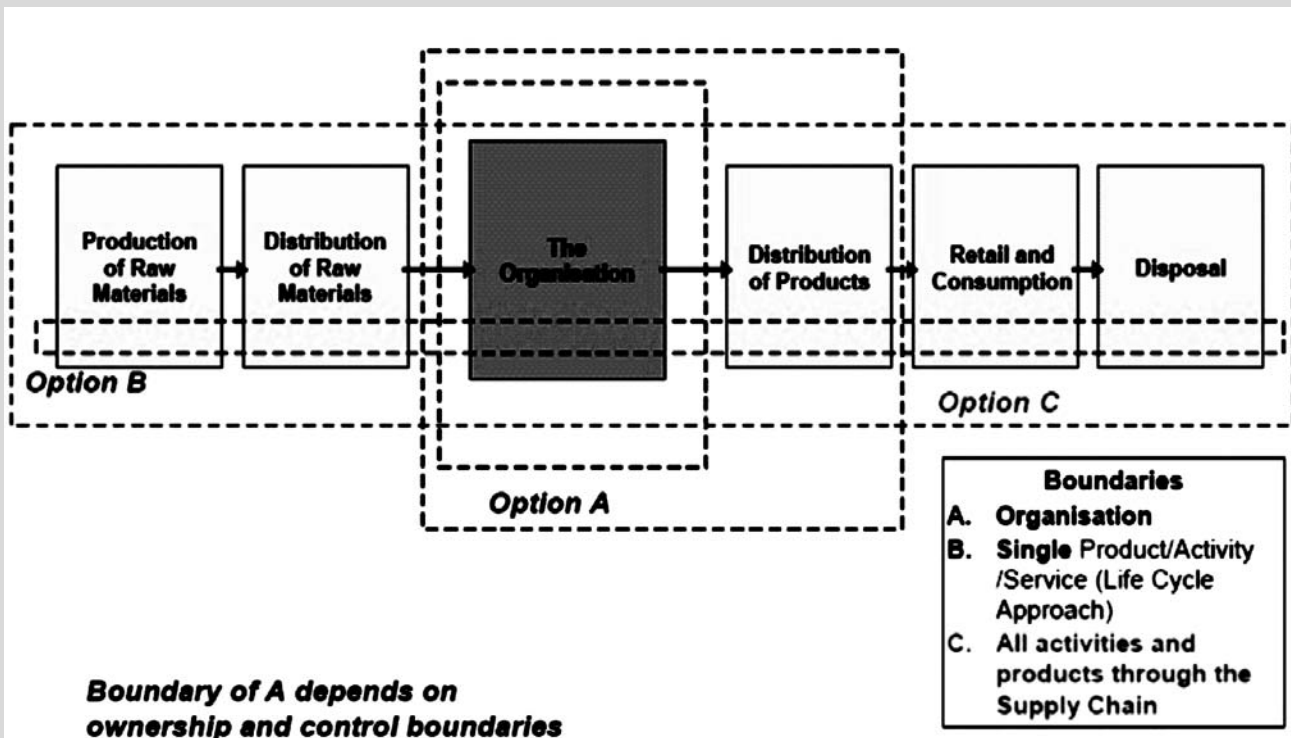

In order to produce a reliable footprint, it is important to follow a structured process and to classify all the possible sources of emissions thoroughly. A common classification is to group and report on emissions by the level of control which an organization has over them.

Constituents of Carbon Footprints

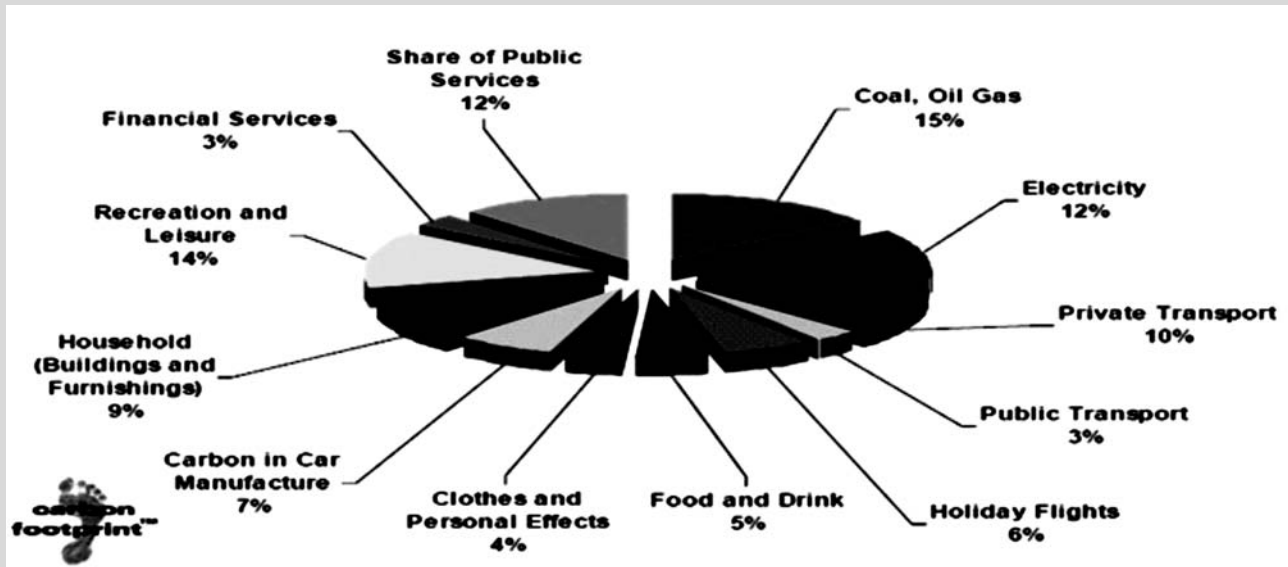

Main reasons behind the calculation of carbon Footprint

1. *To manage the footprint and reduce emissions over time*

- Opportunities for reduction can be identified and prioritized.
- This approach is relatively quick and straightforward.
- More focusing on the areas of greatest savings potential.

2. *To report the footprint accurately to a third party*

- For Marketing and/or Corporate Social Responsibility purposes.
- To fulfill requests from business or retail customers, or from investors.
- To ascertain what level of emissions they need to offset in order to become 'carbon neutral'.

Greenhouse gases and global warming

As greenhouse gases produced by human activities accumulate and their concentration increases in the atmosphere, it causes global warming. The main contributor to global warming is CO₂, which accounts for nearly 80% of emissions from the industrialized countries. The gas is released from burning of fossil fuels: oil, petrol & natural gas. With the rising population and increasing demands on transport and energy the rate at which CO₂ is being released is also accelerating.

Classification of Greenhouse gases

The greenhouse gases emissions (CO₂, CH₄, N₂O, HFCs, PCFs, SF₆) can be classified into three categories;

- Direct emissions that result from activities the organization controls.
- Indirect emissions from the use of electricity.
- Indirect emissions from products and services.

Finally it can be said that carbon footprints carries an enormous importance in sustenance of our daily life of our mother earth and in turn hence lets unite together for its betterment. Lets preserve nation for our future generation.

– By Chet Ram Meena

Attention

**Revised Advertisement Tariff
w.e.f. 01-01-2012 (Jan–Feb 2012 & onwards)**

**reach your
target audience**

**Journal of the TEXTILE Association
advertisement tariff***

| | | | |
|--------------------------|------------------------------|----|--------|
| <input type="checkbox"/> | Front Cover | ₹. | 32,000 |
| <input type="checkbox"/> | Back Cover | ₹. | 28,000 |
| <input type="checkbox"/> | Front Inside – 2 | ₹. | 24,000 |
| <input type="checkbox"/> | Back Inside – 3 | ₹. | 24,000 |
| <input type="checkbox"/> | 1 st Opening Page | ₹. | 18,000 |
| <input type="checkbox"/> | Cover Gate Fold | ₹. | 40,000 |
| <input type="checkbox"/> | Inside Double Spread | ₹. | 30,000 |
| <input type="checkbox"/> | Full Page – Bleed | ₹. | 17,000 |
| <input type="checkbox"/> | Full Page – 4 colour | ₹. | 15,000 |
| <input type="checkbox"/> | Full Page – B/W | ₹. | 10,000 |
| <input type="checkbox"/> | Half Page – 2 colour | ₹. | 10,000 |
| <input type="checkbox"/> | Half Page – B/W | ₹. | 5,000 |



Technical specifications

Size of Magazine : 29 cm x 21 cm
 Print Area : 26 cm x 19 cm
 Frequency : Bi-monthly
 Print Order : 5,000 copies +
 Print Process : CTP

(*Tentative)



Mail at –

THE TEXTILE ASSOCIATION (INDIA)

Pathare House, R. No. 6, 2nd Floor, Next to State Bank of India, 67, Ranade Road, Dadar (W), Mumbai - 400 028.

Phone: (91-22) 2446 1145, Fax: (91-22) 2447 4971

E-mail: taicnt@mtnl.net.in, jb.soma@gmail.com, www.textileassociationindia.org



World Textile Conference Echoing Optimism for the Business

The first ever World Textile Conference was held under the aegis of Textile Association (India) - Central office, with the support of Institute of Chemical technology (formerly known the UDCT) and Office of The Textile Commissioner. The support of the Textile, Apparel and Retail Garment Industries was enormous and the enthusiasm of the delegates attending this conference was simply over whelming. To begin with the Welcome address was given by Mr. D.R. Mehta, President, TAI where as and Mr. Arvind Sinha, Conference Chairman, gave the background of the conference.



Mrs. Rita Menon and others lighting the lamp.



Mr. A.B. Joshi delivering keynote address.

While inaugurating the Conference, the Hon'ble Mrs. Rita Menon, Secretary Textiles, Ministry of Textile, GOI said that theme of the conference "Vision 2020

- Emerging New Opportunities worldwide and Challenging Business strategies" was quite topical and the organizers deserved all admiration for holding such mega event at the most appropriate time. She reminded the several transitions in the policy making which took place from the time of Global Recession necessitating debt restructuring, countering price volatility by raw material security and establishment of integrated Textile and apparel parks, etc. Looking at the best profit lines witnessed in 2010-11, she said that Textile Industry has been successful in securing turn around. Its time, Indian textile Industry should pledge to co-exist with the handloom sector which is producing niche as well as day to day products. Eight centers of Excellence in Technical Textiles are being set up, which itself opens up a new era in this segment. TUFS has been resumed from 28th April 2011 which is more attractive than its earlier manifestation and now 10% additional capital subsidy for new shuttle less looms has been offered and spinner would get an additional 1% subsidy if they establish matching capacity from downstream processing of their yarn. Textile export of US\$ 25 Bn in 2009-10 has been targeted to US\$ 30 Bn in 2010-11. This is achievable target given the Govt. support and opportunities created by a number of free trade agreements with countries like Malaysia, Japan and possibly EU in coming months. Though there are all these opportunities, there are also challenges such as infrastructural bottle-necks, logistic support, rising labour costs, raw material and productivity. Knitwear Industry has been also one of the important contributors to the textile exports and the Govt. has taken initiative in establishing Knitwear Technology Mission with estimated cost of 30.5 crore, to boost the technology. Design studios and training and development of human resources, issues like Social Compliance are being taken seriously and apparel and carpet industry are taking proactive steps in this direction. Zero discharge requirements in Tirupur processing sector is also a challenge, but is the part of environmental accountability and the Government is assisting the Processors and Industry should take this challenge as their responsibility.



Mr. D.R. Mehta offering a memento to Mrs. Rita Menon



Mr. S.R. Bhave receiving Lifetime Meritorious award



Mrs. Rita Menon delivering her conference speech



Mr. B.A. Shah receiving Award

Mrs. Menon finally congratulated all the awardees whom earlier she had felicitated. These included. Mr. S.R. Bhave, who served the TAI as its Hon. Gen Secretary, Mr. M.K. Mehara and Mr. B.A. Shah who too served TAI for more than 4decades in different capacity including its President. Mr. K.C. Tandon, was given Industry Excellence Award and Prof. Dr. M.D. Teli was conferred upon with Academic Excellence Award, first of its kind for his distinguishing contribution to Education and Research in Textile and meritorious contribution to Textile Industry, Associations, Institutions and Govt. Bodies. Every awardees was given certificate, a Memento, a shawl etc. Preceding to this part of the program there were a number of Guests of Honour who spoke on this occasion who also outlined the opportunities faced by Indian Textile Industry and how the industry should take on the challenges emerging out while exploiting these opportunities.



Mr. M.K. Mehra receiving Award



Dr. M.D. Teli receiving Award



Mr. K.C. Tandon receiving Award



Ms. Shraddha compeering the conference



Mrs. Zena Sorabjee receiving felicitation on behalf of Mrs. Zia Mody

Mr. A.B. Joshi, Textile Commissioner highlighted the Govt. initiatives to support the industry. He mentioned that there is sense of optimism and confidence that industry will grow at the rate of 16% in value terms in XI th 5 year plan to reach the market size of US\$ 115 Bn and will attract investment up to Rs 150600 crore and connected benefit of such an investment would be in terms of employment generation for 17Mn people. He asked the Industry to give its input for XIIth plan formulation. However, he cautioned the industry about the need for modernization to achieve international quality in this stiff competitive atmosphere.

Mr. R.D. Udeshi from Reliance Industries Ltd. read out the key note address of Mr. Nikhil Meswani ED., RIL who could not remain present. Mr. Meswani mentions that with rising economy, growing income and young purchasing population around, it will take India to a new paradigm and Industry may grow from current level of US\$ 78 Bn to US\$ 220 by 2020, almost 1.5 times the India's GDP Growth rate. Coming decade will see Polyester grabbing its share up to 75% and a lot of it will be used in specialty fibres for moisture management, temperature regulation, comfort, technical textiles etc. Indian textiles are still consuming 55% of Cotton, but as in China, there will be shift in consumption of fibres in favour of Polyester. Recent trend of use of Recycled polyester and consumption of non-petroleum based polyester in FIFA 2010 for sportswear, indicate that environment friendly textiles will become increasingly important.



Mr. R.D. Udeshi delivering his address



Mr. Dilip Jiwrajka Delivering his speech



Dr. M.D. Teli welcoming Mr. Thomas Babacan

Mr. Dilip Jiwarajka, MD, Alok Industries Ltd, reminded everyone how the global recession is overcome by developed countries and now from 3.6 % contraction in their output during 2009, they are showing 3% growth in 2010 and world economic output is back on positive track with 5% growth and much of the new growth came from developing and emerging economies. He narrated the changing scenario of China where no more labour remains cheap and more purchasing power of local Chinese is boosting domestic demand, which in turn will create unfulfilled demand giving opportunities to India. However, we need to address the rapidly changing fashion trend and there is need to meet the demands of consumers at the lightening speed. Wages are going to increase and textile manufacturers have to be concerned about rising raw material input costs. The global textile market which was US\$ 610Bn in 2008, shrunk to US\$ 510Bn in 2009; However, it is projected to be US\$ 1000 Bn by 2020. The growth drivers for the industry include the rising young population and their rising disposable income, rapid urbanization etc. and industry has to increase the productivity to address the global demands by scaling up the existing capacities.



Prof. R. V. Adivarekar welcoming Mr. Manish Mandhana

As far as India was concerned, out of US\$ 78Bn of Textiles, one third being its exports, said Mr. Manish Mandhana. While speaking as the guest of Honour he said that textiles are ingrained in our life in everything we use in our daily life. How many of us imagined that the Cotton price will increase from Rs.18000 to Rs.62000/candy, an increase by 350% and imagine if someone was trading only in cotton would get the kind of profit, he questioned. For today's generation Technology is no more a mind block and we have to show just how it works and they are ready to accept. While inflation is a major concern, and environment and social compliance are becoming increasingly important, we must tread the path in such a way that whatever we do, we make it sustainable. We need to address the demands of new generation, and manage the talent. Moving to cheaper locations and keeping eye on efficiency almost at all level are important aspects to stand in this competitive environment.



Mr. Manish Mandhana addressing the gathering



Guest of honour Mrs. Zena Soli Sorabjee



Mr. Sanjay Chawla welcoming Mrs. Zena Sorabjee

Mrs. Zena Soli Sorabjee, a Social Worker and Development Practitioner reminded the good efforts put in by Textile Association India in spreading the discourse of Science Religion and Development, which was initially inaugurated a decade ago at the hands of architect of Green Revolution, Prof. M.S. Swaminathan. The work carried out by TAI near Delhi in the field of Science Religion and Development in some of the Garment Units in Delhi did show the application potential of Technology when driven with Ethics to achieve sustainable development and joy of working. She stressed the need to carry out all our activities with ethical bent so that we can route out corrupt practices and our success becomes truly meaningful.

The other guests of honour who spoke briefly on this occasion included Mr. Prashant Agrawal, MD., Bombay Rayon Fashion Ltd., Mr. Ashesh Amin, Director, Apparel and Retail, SKNL, Mr. K. Ramchandra Pillai, CMD, NTC Ltd. and Mr. Thomas Babacan, COO. OC Oerlikon & CEO, Oerlikon Textiles.



Mr. Thomas Babacan addressing the gathering



Dr. Teli offering memento to Mr. Dilip Jiwrajka



Mr. Ashesh Amin addressing the gathering



View of the audience



Mr. K. Ramchandra Pillai addressing the gathering



Mr. K.D. Sanghavi, proposing vote of thanks

The World Textile Conference was the first attempt of TAI - Central Office to organize in a big way which was really a grand success and memorable. There were about 470 delegates and 242 esteemed invitees and guests attended this conference. TAI received highly honored appreciation and compliments from various personalities and organization. This was the record in the history of TAI where such a large august gathering attended than any other conferences. It was told that this happened under the dynamic strong follow-up leader Mr. D.R. Mehta, President, TAI and his entire organizing team members.

There were about 32 papers presented by various eminent Indian and International speakers. All the papers were very interested and informative. No papers were based on technical or machinery base. Following are the session wise papers presented in two days of conference.

The first Technical session started with a presentation from Mr. S.K. Gupta, Group CEO from Reymond UCO Denim, on "India Emerges as a Global Textile Destination". He first described her Current Status as already No.2 destination next to China though 1/9th in size; much smaller in garments and made-ups where Bangladesh and Pakistan are also dominant players and India has insignificant brand presence barring surrounding countries; no specific positioning except alternative to China and is strong in fabric, yarns and full package sourcing; large and growing market for Home- grown and Global brands; low cost fabric manufacturing destination for relocating capacities from the West. India as a Country has following Advantages in various segments: Self-sufficiency in cotton and presence of variety of fibre ; spinning industry strong in-country; large and flexible manufacturing base for suiting/trouser making, shirting, knits, and home textiles in variety of fibre and combinations; large domestic denim and worsted suiting capacities in the organized sector with world class designing and product development capabilities; growing technical textiles industry ;strong and ever growing home market; low labor cost via-a-vis many countries; Govt's support in terms of TUF, EPCG, STPs, Packing credit at concessional rate and Drawbacks/

DEPB and other incentives; Trained/trainable technical and managerial manpower; entrepreneurial drive - many success stories etc.



Mr. S.K. Gupta chairing the session



Conference audience

While indicating a way Forward he said, "Despite infrastructural constraints including high cost of energy and logistics, industry is poised for quantum growth; India unlikely to be anywhere close to No.1 in near future despite garmenting in China turning un-competitive; India to find its own niche building on its inherent strengths; Perhaps to reposition as specialists in certain categories encompassing / embracing other categories in the process; Like Pakistan - in medium count-dyed and printed home textiles as well as bottom weight fabrics; Bangladesh - in low cost garmenting; Indonesia- in high quality low cost TR yarns and greige; Turkey, Tunisia and Morocco - in high quality cotton fabric and garmenting for quick deliveries to EU; Italy - in hi-couture fashion lines-ultimate in fashion; Japan - hi-tech best quality specialty fibres and fabrics etc.;

China - in mass production; Rising Above Competition is important by product specialization. He found the need to focus on high value added

products, divorced from traditional mass production; Build necessary 'aura' projecting India as 'Fashion Capital of Asia' leveraging on designing and flexible / versatile manufacturing capabilities and improving tremendously on service parameters to support this stature; India can then emerge as a 'Global Textile Destination' for Hi- fashion textiles and clothing as manufacturing and designing shifts from historically known centers' of the Western World; Quality leadership coupled with Asian cost structure is surely the right USP for success in times to come. Concerted efforts in this direction can, perhaps, pay higher dividends, he concluded.

that Globalization has led to a profound change in the product sourcing and manufacturing patterns, pursued the world over; Challenges to improve "Input-Cost" efficiencies and "loss" due to product rejections have led to the shift in sourcing focus; Industrial countries are slowly transforming as consuming economies as seen in increased exports of Developing countries; India is most preferred partner after China for global sourcing on cost, quality, high fashion, complete solution, skilled manpower etc.; India's T&C market is growing at the rate of 11% CAGR fuelled by the rapidly increasing domestic demand.



Mr. S.K. Gupta delivering his speech



Mr. Amit Ruparelia presenting his paper



Mrs. Lipika Nair compeering part of the conference



View of the gathering

While talking about the "The Game Changers", he mentioned that aggressiveness in building B2C businesses worldwide, establishing brands and retailing - moving away from traditional low margin B2B models; Corporate to spread wings beyond surrounding countries; Acquisitions could be another solution to break the ice; World is waiting as we all for that D-day.

Shifting Focus in Global Sourcing Towards Asia, Mr. Amit Ruparelia, Chairman, TEXPROCIL said

Then he spoke about what needs to be done and concluded saying that we should concentrate on Integrated value chains with speedy deliveries & Brand Creation; Infrastructure needs investments to the tune of US \$1 trillion projects during the XII Plan (2012-17); Textile & Apparel Parks : Forty (40) textiles park parks supposed to create 7,50,000 jobs; Widening of the product base: Out of 50 T/C Products we are known to supply only 14 and there is need to widen this base; Market Diversifications should also be done as per the relevance and the products;

Dr. Ashok Sanghavi, M.D. AXION Mgt. Consultant while speaking on "How should India Strategise its growth Plans predicted? What will be India's Scenario on Global Textile by 2020: India will be Next to China & U.S .in economic strength, the 3rd largest economy in the world; Booming middle class will enable growth in retail segment; Africa offers big opportunity for Textile Sector; Domestic Market is likely to be more demanding & more competitive; Chinese market is likely to be more lucrative than U.S. / European markets as China will be net Textile Importer; Indian organizations need to open "Research & Development Centers"; There is a need to open textile institutes to focus on knowledge creation; Focus on front end marketing, brand development & distribution for Domestic Market; he also mentioned that there is need to learn about China, and Chinese language and financial Markets will be more developed in Asia region.

as well as for China and in spite of increasing prices, India is still the most cost competitive country. China while meeting the domestic demand may not be able to cater fully to the needs of the world market and hence even if a spillover of even 10% from China's Apparel & Textiles export Market (310 US \$) will mean doubling of India's share in world trade. What is needed is to fill this gap and the commensurate investment has to be made to the tune of Rs. 1.5 lacs crores in the next 10 years. Hence everyone needs to pool in and market should see expansions by existing players, entry of new domestic players and infusion of FDI.

Mr. Sunil Khandelwal, Group CEO, Alok Industries said that the apparel retail has the highest share of about 35% in the overall organized retail market and the current estimated size of the organized apparel market is about Rs. 35000 crores .India will add 130 Mn people in consuming class which will fuel this demand. Integration of fabric to retailing and branding is inevitable for the growth of the industry. He emphasized on building the Indian Textile Brand.



Dr. Ashok Singhavi making his presentation



Mr. Harminder Sahni delivering his speech

While speaking on Resurgence in Indian Textiles, Mr. Harminder Shani indicated that, this is the time to invest in Textile to enhance its growth potential. He said , that constant growing population with increasing per capita real GDP has resulted into increase in the demand in Domestic Market for India



Mrs. Mona Patel presenting the paper on behalf of Mr. Robin Anson



View of the audience

Mr. R.D. Udeshi, President, Polyester Chain, Reliance Industries compared the fibre per capita consumption and indicated growth potential for Polyester. Reliance being poised to make a huge investment in Polyester Sector of about US\$10Bn, one should expect the growth in this segment, he opined.



Mr. R.D. Udeshi chairing the session

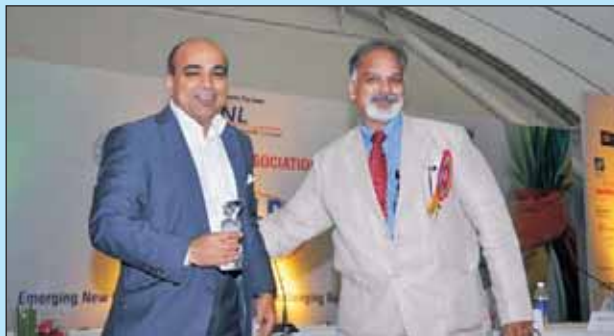

Mr. Arvind Sinha presenting memento to Mr. Premal Udani

Mr. Collin Purvis while talking on Opportunities and Business Strategies in Textiles: The Role of Man-made fibres, said that 73 million tonnes of fibres was consumed in textiles in 2010 and Polyester of about 34 million tonnes and its consumption will further increase in 2011 and due to the possibility of engineering the fibres. A wide range of fibres, each with its own characteristics such as high performance/cost ratio could be obtained. Versatility, durability and resistance to degradation are other key factors for Polyester application. What is needed is the Good environmental story and thus the fibre producers should show low energy and water usage in processing and use emission controls, recycling, durability and safety of product. Responsible man-made fibre producers have to distinctly demonstrate this aspect, he concluded.



Mr. Collin Purvis presenting the paper



Prof. Jiri Militky presenting his paper

Prof. Jiri Militky while speaking on Seamless Frontiers of Apparel, Textile and Fibers: An Emerging Paradigm- narrated how these substrates of different origin are serving human being in innumerable ways: Clothing, Protection, Medical Field, Information, smart clothing's, Infrastructure and so on.

He said Bio, Nano, Information Technology and Technical Textiles' will take centre stage. He gave a number of examples of Research and Development in this field which of course readers at this juncture may not like to go into details. And finally he concluded that the master Textile Engineer is like a SPIDER.

Dr. Rakshit from Reliance gave a scenario of new products of Reliance which have specialty uses. Such as Flame retardant fibre, Antibacterial fibre, High Tenacity Polyester, and so on.



Dr. Rakshit making his presentation



Prof. Pertti Nousiainen making his presentation

Professor Pertti Nousiainen spoke on Medical Textiles and its advanced applications off the body, on the body and inside the human body .He gave a number of such applications in Tissue Engineering, Heart valves, Kidneys and so on. I feel earlier we were saying Womb to tomb... Now we need to say Cell to Hell. He took stock of Biomaterial Market, how it is growing and what is its future scope.

Dr. Chatterjee spoke on WINNING STRATEGIES for growth of Textiles in Gujarat and how Gujarat Govt. has formed investment friendly policy and created conducive environment.



Dr. Chatterjee making his presentation



View of the audience

Mr. Ashish Dhir, Asso. VP Technopack presented key learning from China which included integration of supply chain & economies of scale; Brand Building; Research, Development and Innovation; Focus on efficiencies in supply chain ;Close "working" relationship with Customers; Geographical outreach, Aggressive government pro-industry measures; Synergy in competition and then he described the secrets of Success of Indian Companies.



Mr. Ashesh Amin chairing the panel discussion session



Mr. Ashish Dhir presenting his paper

Mr. Arvind Sinha's Presentation was full of his experiences of China and he gave good examples and Do's and Don'ts as far as making business with China was concerned. Becoming member of Local Chinese Business Body was one of his important suggestions to protect your interest, beside studying well with whom you do business, respect to Hierarchy, Politics, etc.

While speaking on Opportunities for Textiles in Composites, Mr. Julian Ellis discussed different types of Composites involving fibre reinforcement. These composites are used in various sectors such as Automobiles, Aircrafts and Spacecrafts, Defence etc. due to their lighter weight, high strength etc.

their market will grow. He talked about the kind of Fibres used in them and why.

Mr. Arvind Sinha while speaking on Defense Textiles and Camouflage fabrics talked about Defense Forces worldwide are spending more than US\$1600 Bn every year and 3% to 5% share of above mentioned figures which makes it more than US\$50 Bn is on textile products. He narrated different types of material used here in Defense and also the quality parameters which are required to be maintained. Parachutes, Aircraft fuel cells, Sandbags, Tents and shelters, Sheets, Blankets and hospital supplies, Airplane panels, Ammunition bags/pouches, and Fabric for bullet-proof vests/helmets, Chemical protective suits, Rafts, etc. This opens up a lot of OPPRTUNITIES for Diversification. Technical Textile is thus very important. He discussed Camouflage Fabrics and what precautions one need to take. Camouflage Fabrics consumed is approximately 350 million meters and is growing at the rate of 10% per year. According to him, India is well positioned to address this need.

Mr. Adrien Wilson spoke on how Sustainability will be critical for India's nonwovens boom. Days of petroleum-based synthetic fibres may soon be numbered.

For the nonwoven fabrics employed in the •23 Bn hygienic disposables market, Procter & Gamble has announced that it intends to switch to 100% renewable or recycled materials.25% of this would be from Renewable fibres to begin with. Its 50 products sale is \$79 Bn - this is still a considerable commitment. They want to go for Zero waste. Bioplastics will be in demand. PLA fibres capacity will increase. In India, this industry as well as Filtration industry requiring Non- wovens and thus it will grow rapidly.



Mr. Akhtar Amin chairing the session



Mr.B. Balamurugan of Textile Committee delivering his address



Mr. Arvind Sinha making his presentation



Stall of Govt. of Gujarat at the conference

Mr. Andrew Ola spoke on Indian Denim Industry in global perspective, its Growth opportunities and Challenges vis-a-vis other denim supplying countries. China produced about 2.5 Bn yds of indigo denim in 2010. India will produce 650-700 million yds of denim this year. Bangladesh and Pakistan have also become massive indigo denim

producers allowing the region, the sub-continent region to produce 1.2 billion yds of denim this year. India's largest "current" competitor is China. The denim "demand" is related to four factors: Quality - technically and or creatively; Price; Location in regards to production and Service. Future demand will come from taking market share away from China within the US, European and Japanese markets. The growing Indian domestic market will also need more denim. Speaking on Application of Ecological and Environmental practices Mr. Enrique Silla discussed the Ecology, efficiency and ethical aspects of Denim making. He talked about developments using laser beams so that one can avoid amount of Chemicals and waters to be used.

Mr. Koosai Laheri, Director, KPMG spoke on IFRS and its impact on corporate India. He gave detailed survey of areas such as Revenue, Fixed Assets, Consolidation, Merger and Acquisition, Equity and Liability and other financial instruments, stock options and presentations and disclosures etc in which such impact will be felt. Mr. T.K .Sengupta gave detail presentation on Valuation techniques and assessment of Fair value and its role in convergence to IFRS.



Mr. T.K. Sengupta delivering his presentation



Mr. J.B. Soma offering a memento to Mr. T.K. Sengupta

Dr. Nair and Mr. Pandian while speaking on Textile Processing Machinery put forward the principles of development in the modern machinery which are mainly economy and ecology. E-control process as well as combine pretreatment (scouring and bleaching) along with mercerization was also explained by them along with their merits. Dr Nair mentioned about what is in offing as far as new machinery is concerned.



Mr. Bachkaniwala chairing the session



Dr. H.V.S. Murthy presenting memento to Mr. Bachkaniwala

In the last session there was a paper on PVA copolymer and its recovery by Mr. Elliot Echt of DuPont and of Mr. Manjit Singh, MD, Paramount spoke on QUALITY: The new Facades in Coming Decades. Mr. Manjit Singh drew home the point of running the business with responsibility and what needs to be done to maintain such high standard of quality.

It is taken for granted that the aspects such as Fitness to USE, Meeting Requirements of the Customer, Giving the VERY BEST, Surpassing the Customers Expectations and bringing WOW to the Customer etc are part and parcel when we say we offer quality. Bringing new facades to Quality means health and

safety, the buyer wants their Merchandise prepared by using no child labour. We need to reduce Carbon Footprints. Buyer wants their Merchandise Waste to be Recyclable. We need to Think GREEN and SAVE the Planet. It was very interesting presentation which also evoked a good response sending home clear signal that Ethics in business has strong place for its sustenance.



Dr. P.R. Roy chairing the session



Mr. V.D. Zope offering a memento to Dr. P.R. Roy

Mr. R.C. Kesar further carried this message with his presentation on Responsible Business Practices. He discussed various elements of such practices which are ecological, social and referred to our conduct at market place and business, ethical governance, and then he narrated OGTC's plan to reduce Carbon footprints.



Dr. Rishi Jamdagni chairing the session



Mr. R.C. Kesar delivering his presentation

Finally there was valedictory session in which summing up was done by Prof. Dr. M.D. Teli, Dean, ICT, Mumbai. He covered almost every paper with the brief points each author made during their presentations.



Dr. Kim Gandhi giving his feedback of conference



Dr. Teli summing-up the conference

This was followed by actual response by a number of delegates who praised the arrangement of the Conference and kind of Food for thought it provided. The conference where in almost 10 Technical sessions were devoted for Technical and managerial issues and most of the delegates were there till the end, spoke for the kind of interest it generated and success

it met. Panel discussion attended by eminent industrialists and CEOs and papers presented by Senior authorities in various Industries speak for the success of conference further. It made India's growth story. It discussed opportunities, challenges and also kind of strategy required and from that point of view the conference was highly successful. Most of the respondents who spoke, cheered Mr. Mehta and his TAI Team, Mr. Sanjay Chawla and his Team, Dr. Teli and ICT team and Compeers Ms. Shraddha and Lipika. Conference ended with Fashion show by Dr. Aditi Govitrikar and Shraddha Nikam.

the faculty members of Institute of Chemical Technology wonderfully managed the stage performance under the guidance of Dr. M.D. Teli, Dean of ICT. Along with this Shraddha Teli and Lipika Nair have wonderfully worked as Comparers with their ornamentally sweet voice.



Dr. Aditi Govitrikar presenting her fashion show



Mr. D.R. Mehta addressing valedictory session



Audience enjoying the fashion show



Mr. V.D. Zope proposing vote of thanks

Friends, it was indeed a mega show and in all accounts, the Organizers as well as the Sponsors deserve Congratulations and Three Cheers. All the papers were very knowledgeable and the speakers also of high profile with right subjects. Arvind Sinha, Conference Chairman, Sanjay Chawla, Conference Convenor, K.D. Sanghvi, Chairman - TAI and J.B. Soma really worked tirelessly to perform this World Textile Conference a grand success. Students and

It is really watershed event before the tide in global textiles turns in favour of India. The delegates, invitees and participants unanimously made telling remark which was echoed by D.R. Mehta, President, TAI "At this World Textile Conference, delegates had come with a definite purpose. They came not just as visitor or onlookers but with objectives defined. The delegates right from the shop floor level to decision makers at the highest level. They came together so that they could learn, evaluate and take decisions to innovate, implement and enrich their business to meet global challenges".

- Prof. M. D. Teli, ICT, Mumbai - 19.
E-mail : md.teli@ictmumbai.edu.in



The Textile Association (India)

Expresses deep sense of gratitude to the Industry, Supporting Partners, Endorsing Trade Bodies, Advertisers, Speakers, Delegates and Media For extending their overwhelming support to make this Conference a mega success



TAI - Ahmedabad Unit

1ST APRIL, 2011

Unit members attended workshop organized by the Textile Committee & Development Commissioner (Handicrafts) Ministry of Textile, GOI on “Post GI Initiatives for Selected Craft Indications of Gujarat” held on 1st April, 2011 at Courtyard by Marriott, Ahmedabad. Shri A. K. Joti, Chief Secretary, Govt. of Gujarat was the Chief Guest of the function while Shri Guest of honour was Shri Maheshwar Sahu, IAS, Principal Secretary (I & M), Govt. of Gujarat. Shri A. B. Joshi, Textile Commissioner, Govt. of India, Mumbai was invited as special guest and delivered his special speech during the function. The object of the workshop was for promoting brand and marketing linkage of five unique handcrafted products of Gujarat. The products are (i) Bandhani (ii) Surat Zari craft (iii) Agate Stones (iv), Sankheda furniture and (v) Kutch Embroidery. The workshop used as a platform for showcasing these IPR protected products and preparing the road map for post GI interventions so that the IPR protection could be converted to langible benefits for the artists.

9th APRIL, 2011

Office Bearers and Trustee of the TAI-Ahmedabad Unit attended conference on “Globalization, Good Governance & Democracy-The Interface of India@75” held on 9th April, 2011 at



L-R: V. A. Trivedi, Edward Menezes, A. D. Bhagat, Mrs. Sharma

Hotel St Lurn, Ushmanpura, Ahmedabad. This conference organized by the CII-YI Ahmedabad during the celebration of its Annual Day 2011. Shri Maheshwar Sahu, IAS, Principal Secretary (I & M), Govt. of Gujarat was the chief guest of the function. Mr. Madhur Todi, Chairman – YI Ahmedabad chapter and MD of Mere Money Advisors Pvt Ltd welcomed and given opening Remarks & Review of Yi Activity 2010-11. Mr. Pravit Parikh, Co-chairman-Ti Ahmedabad Chapter and director of Systems Dynamics (Software) Pvt. Ltd delivered his concluding remarks at the inaugural function.

17th APRIL, 2011

Office Bearers and some of the Managing Committee Members attended the Conference on “GUJARAT VYAPAR UDYOG” organized by GCCI held on 17th April, 2011 at Gujarat University Convention Hall, Drive-in Road, Ahmedabad. This conference inaugurated by the Chief Minister of Govt. of Gujarat Shri Narandra Modi.

28th APRIL, 2011

The Textile Association (India) Ahmedabad Unit organized a memorial lecture of Late Shri Rajendra Sharma on “Enzymes in Textile Processing” held on 28th April, 2011 at AC meeting room of Dinesh Hall, Ashram Road, Ahmedabad. Shri A. D. Bhagat, Vice President of TAI-Ahmedabad Unit delivered his welcome address. Mr. Edward Menezes, Director, Rossari Biotech Limited, Mumbai was speaker of the function. The Association invited Mrs. Sharma as a special guest of this memorial lecture. Mr. Edward delivered speech on the subject matter while Mrs. Sharma spoke something about the programme organized as memorial of her husband who had rendered his service with Rossari Biotech Ltd, at Ahmedabad and was one of the active members of The Textile Association (India) Ahmedabad Unit. Shri V. A. Trivedi, Hon. Secretary proposed the vote of thanks. More than 80 members of Association attended the lecture.

Read & Advertise in **Journal of The TEXTILE Association**
Most preferred and widely circulated bimonthly Journal
For details : email: taicnt@mtnl.net.in

72nd
year

TAI - Delhi Unit

Announcement 67th All India Textile Conference
Annual conference of The Textile Association of India.

The Textile Association (India)
 The Textile Association (India) is the leading and the largest national body of textile professionals in India. TAI was established in the year 1939 and has been serving the Indian Textile Industry for over 7 decades. Currently, there are 27 affiliated units at various textile centers in the country, accounting for member strength of over 22,000 from pan India. TA(I) is the founder member of Federation of Asian Professional Textile Associations with Professional Textile Associations of Taiwan, South Korea, Japan, Hong Kong and Australia being the other members. TA(I) is also the founder member of Federation of Asian Professional Textile Associations (FAFTA) and co-sponsor of the International Textile Machinery Exhibition (India-ITME Society).

The Textile Association (India) organizes an annual textile conference, known as *All India Textile Conference*, which has been organized every year since 1944. The AITC is a much sought after annual event, attended by a large number of textile professionals from all over the country and also from abroad. The AITC has been inaugurated by the Hon. President and Prime Minister of India in the past.*The 67th edition of the All India Textile Conference is being hosted by Delhi Unit of TA(I). *

TAI - Delhi Unit

The Delhi unit of The Textile

Association (India) was established in 1965 and today has over 1600 members. It is the third largest TAI unit in the country. The Delhi unit has organized several successful conferences in the past, including the 1st Asian Textile Conference in the year 1991 and the 7 th Asian Textile Conference in the year 2003.

67th AITC: Textile & Clothing - Emerging Global Scenario

The 67th edition of the All India Textile Conference shall focus on the past and future of the textile and clothing industry, in the global context. *The theme of the conference is "Textile & Clothing - Emerging Global Scenario".*

The textile and clothing sector in India has undergone a series of transformations over the last few years, due to a combination of technological changes, evolution of the different production costs, and the emergence of important international competitors.

Considering the significance and contribution of textile sector in national economy, initiative and efforts need to be made to take urgent and adequate steps to attract investment and encourage wide spread development and growth in this sector.

The 67th All India Textile Conference will offer a platform to discuss the recent and emerging technologies fast being adopted in the rapidly evolving textile sector where competition has assumed global dimensions. The conference also offers a platform to discuss efficient management techniques and throw light on the emerging management concepts which have been proven to be beneficial. The conference will focus on effective

management of all the resources such as machinery, material, manpower, marketing, finance, production and sustainability.

Venue & Dates :

The conference is scheduled for *4th & 5th February, 2012* (Sat. & Sun.) at *Habitat World*, India Habitat Center, Lodhi Road, New Delhi.

Contact:

Mr. Ashok Juneja, Mr. R. Dudeja,
 Tel.: +91 11 2575 0224

TAI - Vidharbha Unit

TAI Vidharbha Unit's Fashion meet, a thumping success

The Vidharbha Unit of the Textile Association (India) recently organised the national fashion conference "Garment – Era 2011" in Nagpur in association with Texcellence Garment Advisor, a new initiative of Texcellence Institute of Design, Nagpur, on "Fashion – Garment industry: Opportunities & Road Ahead".

Mr. Hemant Sonare, Hon. Secretary of the Vidharbha Unit of TAI, began the proceedings by outlining the objectives of the conference. The mega conference would focus on the emerging opportunities and prepare garment and fashion professionals for the road ahead.

Mr. Sonare urged all the delegates to go for fashion & garment entrepreneurship and promised all support to budding entrepreneurs who wished to start their own business in this vital sector.

In her inaugural address, Dr. Pallavi Darade, Additional Commissioner

of Income Tax, Nagpur, who was the Chief Guest of the conference, appreciated the efforts of the organisers for such a unique conference in Nagpur, and appealed to all the participants to take full advantage of this rare opportunity to listen to the experts on quality improvement, productivity enhancement, technology update and capacity building. The conference provided an ideal platform for exchange of information, ideas and experience sharing with fashion gurus from all across India.

She expressed happiness over the greater involvement and percentage of working women in this industry compared to any other industry. The industry would contribute strongly for empowerment of women in the region in the coming years.

The event covered a gamut of contemporary topics by experts who suggested new ideas and business opportunities for budding entrepreneurs.

The first technical session started after the inaugural session was moderated by the Vice Chairman, TAI-Vidharbha, and Sr. Manager, Raymond Textile Ltd., Mr. M.M. Birader. With him were Prof. Nien Siao, Head of Fashion Design Department, and Prof. Sarita Karandikar, Associate Professor & course leader from the Pearl Academy of Fashion, New Delhi.

Prof. Nien Siao expressed her concern over the social and environmental issues. Increasing pollution from vehicles and industrial units, deforestation, excessive use of chemicals, plastics, metals and other non-biodegradable material, and expanding landfill sites are having their devastating impact on the environment. Extensive use of natural resources and superfluous production and use of man-made articles, along with tremendous waste generation, is adversely affecting the environment. This underlines the need to minimize environmental damages and make the earth a better place to

live in. Being green and ethical across the clothing supply chain is no longer an option but a commercial and environmental necessity.

Next on the agenda was a brilliant presentation by Prof. Sarita Karandikar, in her presentation on 3 Fs of styling – Fashion, Fabric and Forms – elaborated on issues related to purchasing power, travel opportunities and aspirational acquisitions to bridge the gap between these needs and demands. The pace to instant gratification of all wants and desires is increasing, and hence the need to match that pace through styled perspectives to attract the consumer.

The post-lunch session was moderated by the renowned textile consultant of the region, Prof. S.P. Gadage. In his introductory remarks, he said all facets of the industry – textiles, garmenting, technology, manpower and marketing – would be presented in the second technical session. With him were Mr. Rajeev Sadhwani, Head (West Region), Mehala Machines India Ltd., Prof. Shakeel Iqbal, Associate Professor, National Institute of Design, Hyderabad, Mr. Ranjan Vashishta, Chief Consultant, LBM Consulting Group, Gurgaon, and Mr. Sanjeev Bhartiya, Vice President, Uniworth Textiles Ltd.

Mr. Rajeev Sadhwani began with his presentation which dwelt on the technological advancement in garment industry, and urged participants to follow and adopt the new technology to enhance productivity as well as quality. Technology combined with aesthetics is promoted through multiple media exposure.



Dr. Pallavi Darade, Additional Commissioner of Income Tax, Nagpur, addressing the conference. The others (from left) are Prof. Sarita Karandikar, Associate Professor & course leader from the Pearl Academy of Fashion, New Delhi, Mr. Hemant Sonare, Hon. Secretary, TAI Vidharbha Unit, Prof. Nien Siao, Head of Fashion Design Department, Prof. D.S. Kulkarni, Vice President, TAI - Vidharbha Unit, Mr. Ranjan Vashishta, Chief Consultant, LBM Consulting Group, Gurgaon, and Prof. Shakeel Iqbal, Associate Professor, National Institute of Design, Hyderabad

Mr. Ranjan Vasishtha, in his presentation on "Opportunities & Challenges being faced by Garment Industry", said India has all the potential to develop as a leader in garment production. Besides lean principles in garment industry, he expanded the concept of value addition and urged everyone to avoid unnecessary men and material movement and inspection. Fashion is changing faster. Most of the famous world brands are moving from two seasons to four seasons.

Mr. Shakeel Iqbal spoke on value addition & entrepreneurship opportunities in textiles. He shared his ideas with the participants regarding latest innovation for higher yarn, fabric quality and productivity. As one moves across the value chain, i.e., fabrics and

garments, the opportunities are greater for profit maximization.

The last session was presided over by Mr. Sanjeev Bhartia, Vice President, Sales & Marketing, Uniworth Textiles Ltd. He spoke on the latest fashion trends and consumer preferences and briefed the participants on the available career opportunities in the clothing & garment industry.

The conference was very much interactive and informative. Several distinguished fashion designers, garment manufacturers, boutique owners, retailers, academic institutions, faculties, fashion & textile technology students from all across Vidharbha participated in the deliberations.

Earlier, welcoming the gathering, Prof. D.S. Kulkarni, Vice President, TAI - Vidharbha Unit, shared his views regarding development of the fashion & garment industry of the region. He gave a brief account of all the activities of TAI - Vidharbha and statistically highlighted the current position & career growth opportunities available in this sector for new entrepreneurs and women.

The conference concluded with a fashion show extravaganza organised by Texcellence Institute of Design in association with Kanhya City, a project by Jham Builders & Developers, Nagpur. The student designers from Texcellence Institute displayed their innovative and creative designs. This presentation was well appreciated by all the delegates.

Half Day Seminar on

"Flame Retardant Textiles"

Schedule of Seminar

To be conducted by BTRA at the following Centres

- ☛ Mumbai : 8th July 2011
- ☛ Bangalore : 2nd Week of August
- ☛ Kolkata : 4th Week of August
- ☛ Bhilvara : 1st Week of September 2011
- ☛ Chennai : 1st Week of October 2011

Participation by Invitation only and hence no delegate fees charged
Only Registration in advance is required. Registration form is enclosed

Please send your confirmation either by

Fax : 022-2500 0459 or E-mail : btra@vsnl.com

Contact : Bombay Textile Research Association

L B S Marg, Ghatkopar (W), Mumbai - 400 086

Website : www.btraindia.com

Tel. : 022-2500 3651/2652 • Fax : 022-2500 0459

A.T.E. joins hands with Bajaj Steel for ginning solutions

Textile engineering major A.T.E. Enterprises Private Limited has now joined hands with Bajaj Steel Industries Ltd (BSIL) for providing ginning solutions to the spinning industry.

Bajaj Steel Industries Limited, (BSIL), with over 5 decades of experience, is a pioneer in cotton ginning & pressing plant and machinery in India, offering internationally recognized ginning solutions. BSIL has built on its own expertise with technical collaboration with Continental Eagle Corporation, U.S.A., Samuel Jackson Incorporated, U.S.A., and the Central Institute for Research on Cotton Technology (CIRCOT), ICAR, Govt. of India.

A.T.E. has recently forayed into garment machinery. With this latest entry into ginning machinery sales, A.T.E. has truly emerged an end-to-end – ginning to garmenting – solution provider, a unique position in the textile machinery segment.

For many of the spinning mills contemplating backward integration into ginning to get quality cotton, A.T.E.'s entry into this segment is a welcome development, as it offers the comfort and convenience of dealing with a single source for a range of products and services.

BSIL's product range covers the complete equipment required for an automatic ginning and delinting project, consisting of:

- Automatic feeding and cleaning machines
- Advanced ginning machines.
- Heavy duty automatic bale presses
- Lint conveying, baling and humidification
- Delinting and decorticating plants machinery etc.



According to Mr Laxmikant Rathi, Vice President of A.T.E., if the trash in bale cotton can be controlled to be below 2%, it will result in the following advantages:

- Optimum natural fibre parameters
- Reduction of waste in blow room and carding
- Power consumption at filter
- Reduced short fiber content
- Help to reduce TM at spinning and ultimately increase spinning production
- Improve yarn realization by 2 to 3%

As the Bajaj ginning plant is designed to control the trash below 2%, it thus offers enormous benefits to its users.

Mr M K Sharma, President, BSIL, expressed satisfaction on the tie-up with A.T.E. He said that as A.T.E. is well established in the Indian textile industry, it would be able to promote BSIL products to the organized spinning industry for their backward integration into ginning, so that they get the desired quality cotton.



subscribe to Journal of the TEXTILE Association

Subscription charges (in Rs.)

| Term | Issues | You Pay |
|---------|--------|---------|
| 1 year | 6 | 500 |
| 2 years | 12 | 900 |
| 3 years | 18 | 1300 |

Speicher, Switzerland and Remscheid, Germany, May 10, 2011



The Fiber Year Consulting and Oerlikon Textile take pride in announcing that the new Fiber Year 2011 report has been published today. It continues a series of issues covering the world textile and nonwovens industry that has started beginning of the 2000's after Akzo had decided to discontinue this service they had provided more than three decades. Due to changes in the last year, the new report is now available to purchase at a rate of CHF490.– at www.thefiberyear.com.

The world textile industry in 2010 has experienced the most potent growth in twenty-five years. Manufacturing volumes of natural and manmade fibers rocketed upwards by 8.6%, or 6.4 million tonnes, at 80.8 million tonnes. This corresponds to an average per capita consumption of 11.8 kg.

Thus, an average annual fiber growth of 3.4% in this decade compares to a yearly population rise of 1.2% in that time frame.

While cellulosic and synthetic fiber segments both produced double-digit growth, natural fiber expansion was content with a lean 2.2% expansion.

All major manmade fibers with the exception of acrylics were lifted at double-digit rates. Polyester industrial filament yarn even jumped up by spectacular 37%. Viscose fibers produced a record-breaking growth of 17%.

A historical price explosion for cotton with a new all-time high on December 21 at 186 U.S. cents per pound, more than duplication from August, has led to generally surging fiber raw material prices. To a certain extent, it has also favored the usage of competing fibers at comparatively lower costs.

More importantly, world textile industry has come to the conclusion that times of low-priced cotton are seemingly over. Cotton stocks are predicted to remain below the long-term average and future outlook is rather depressed. Although next season's acreage is anticipated to strongly expand yielding a large crop next season, future expansion will be constricted by limitations from arable land to secure food security and water. Hence,

two fiber types will have the best of all growth opportunities – polyester and viscose.

Another driving force for growth, although comparatively small-sized in volume terms, will be carbon fiber. This technologically advanced fiber will continue to produce double-digit growth rates for the years to come. Trendsetting developments in the aircraft and automotive industries may spur future demand.

The previous year's rapid rise of demand was first of all result of the global economic recovery. Increasing incomes, lower unemployment and rising consumer confidence have led to higher expenditures for clothing and increasing demand in significant industries for technical textiles.

Thus, textile and industrial applications have enjoyed encouraging growth. Minor flaw was the performance in the carpet business that was still suffering from the financial crisis, revival of business was a little time-delayed.

However, last year's performance was increasingly burdened with steadily rising inflation rates in emerging countries, due to higher food prices and energy costs in particular. On the one hand, it may cause a new increase in wages. On the other hand, it has definitely resulted in surging investments in new machinery. We have seen above-average installations of new machinery in cotton and manmade fiber spinning as well as processing. Instead of accumulating cash flow surpluses, it seemed to be more appealing to switch to working capital and order new equipment for expansion or modernization.

Global textile machinery manufacturing industry was not prepared for this run on new orders all of a sudden. This has resulted in delayed time of delivery far above the ordinary level. While an outstanding order backlog appears to be good news at first sight, it may also lead to an exceptional redirection of urgently required demand for capital goods.

Thus, a considerable step-up in the trade of second hand machines has been observed. A first wave of trading used equipment was noticeable around the abolition of textile quotas. At that time, machinery from the western hemisphere was moving East. At the moment, extensive movement is existing within the Asian region.

Comber LK64

New Benchmark in Combing Technology

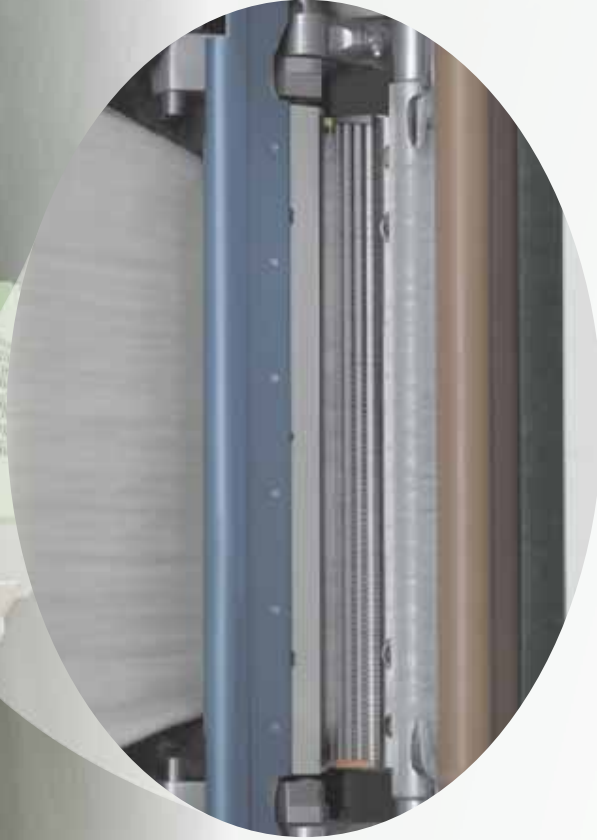

Comber LK64 with the "MCDP" technology sets a new benchmark in combing with production rate of upto 1.7 tons/day. The optimal selection of short fibres enables the machine to run at higher speeds without straining the fibre. The specially designed technological components help in efficient removal of short fibres.

Salient Features

- Production upto 1.7 tons per day
- MCDP Technology for high speed operation
- 3/3 Pneumatically loaded drafting system
- Specially profiled light weight aluminium alloy nippers
- Piecing assistance in drafting zone
- Timing belt drive for noiseless transmission
- Modular construction

LAKSHMI MACHINE WORKS LIMITED

Perianaickenpalayam, Coimbatore - 641 020 India.
Phone : +91 422 3022255 Fax : +91 422 2692541
E-mail : sales@lmw.co.in / exports@lmw.co.in www.lakshrimach.com

Leadership through Excellence

innovation
& VALUE
creation



Helping spin yarns that will weave fabric of mutual reliance & goodwill for you worldwide



Visit us at :
Hall H2,
Stall C 123



ITMA 2011
www.itma.com
22-29 September
Fira de Barcelona
Barcelona, Spain

World Series Rings

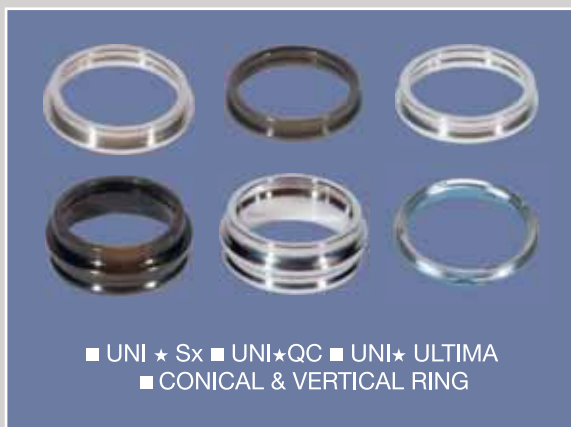

Ring Travellers



UNITECH TEXMECH PVT. LTD.

W-28, M.I.D.C. Bhosari Industrial Area,
Pune - 411 026, INDIA.

Tel. : +91 20 27120379, 27127674

Fax : +91 20 27126272, 27656315

Email : admin@unitechtextmech.com

sales@unitechtextmech.com

URL: www.unitechtextmech.com

genesisads.com

Serving Spinning World since 1976

The investment boom provides the ground for assuming that market actors are confident about the further trend of business. Affiliated with expected good economic growth the increase in textile consumption should continue in 2011.

For more information:

Andreas W. Engelhardt or André Wissenberg
The Fiber Year GmbH Oerlikon Textile
info@thefiberyear.com andre.wissenberg@oerlikon.com
Tel: +41 71 450 06 82 Tel: +49 2191 67 23 31
Cell: +41 79 952 41 50 Cell: +49 151 14 65 05 21

Seminar about HOHENSTEIN Oeko-Tex® certification

Keeping in mind the growing demand for eco-friendly textiles and hence the increase in interest for Oeko-Tex® Standard 100 certification amongst Indian garment and made-up goods exporters and raw material suppliers along the supply chain, Hohenstein India Pvt

Ltd will hold a seminar on 20 July 2011 in Ahmedabad to propagate interest and awareness of this quality benchmark in the field of textiles.

This seminar will provide comprehensive information about the Oeko-Tex® testing and certification procedures, the testing criteria and limit values as well as the impact of Oeko-Tex® certification on international business. As a special feature this year, there will be a session on the Eco-Passport Certificate, which is a very important and critical certification for dyes, pigments, chemicals, auxiliaries etc. Representatives from quality assurance and marketing departments from all stages of textile production, buying agents and their suppliers are welcome to participate in these events.

In the fast evolving world of consumer behaviour where buyers are constantly on the look-out for value addition in their purchase decisions, the Oeko-Tex® label reliably indicates to interested end users the additional benefit of tested safety for skin-friendly clothing, home textiles and other textile products. In this way, the test label plays an important decision-making tool while purchasing textile products.

In addition to that, the Oeko-Tex® certificate has come to be considered a necessity by various European buyers; American buyers are also increasingly demanding more of the same. Thus, the Oeko-Tex® label is an ideal marketing tool for all who need to market their products to Europe and the USA, because it incorporates the requirements of the European legislation as well as the US laws.

Besides, there is an online form available in the "News" section of www.hohenstein.in. Preference will be given on first come first serve basis.

Seminar details:

Date: 20 July 2011
Time: 09:30 a.m. - 01:30 p.m. (followed by lunch)
Venue: Country Inn & Suits
Near S.A.L. Hospital
Ahmedabad - 380054 Gujarat, INDIA

The seminars are free of charge to the participants, but pre-registration is obligatory. Interested persons can get detailed information and register by mail to g.sumit@hohenstein.in and vinay@hohenstein.in.

Advertise with us
ON
TAI Website
Banners
Visit
www.textileassociationindia.org

Dr. N. N. Mahapatra has been appointed as Chairman of WISTI (West India Section of the Textile Institute, Manchester). He is also Hon. Jt Gen. Secretary of The Textile Association (India), Central Office



Dr. Mahapatra is having 27 years of experience in textile industries in India and abroad . He has worked in all big textile houses like Birlas, Reliance, Raymond (Kenya) Churchgate Group (Nigeria), GSL, (formerly Gujarat Spinners Ltd), LNJ Bhilwara (RSWM) Group in various senior capacities.

In the year 2007 he was also awarded C Col FSDC (U.K) and C Text FTI (Manchester). In the year 2008 he was awarded the F.T.A from the Textile Association of India and F.I.C from the Institution of Chemists ,Kolkata .In the year 2009 he was awarded the F.I.E from The Institution of Engineers (India) .He is a Senior Member of American Association of Textile Chemists and Colourists. He is a Life Member of Indian Institute of Chemical Engineers, Indian Chemical Society, Indian Colour Society, UDCT Alumni Association, Indian Science Congress Association, Indian Association for Science Fiction. He is a Patron Member of Association of Chemical Technologist (India) Ahmedabad. He is also member of All India Management Association. In 2008 his name is included in American Biographical Institute. Inc (U.S.A) for professional recognition and peer communication.

He has contributed more than 120 papers in textile journals, having international circulation and presented more than 10 technical papers in various seminars in the country and abroad. He has traveled countries like Australia, U.K., Dubai, Kenya, Nigeria, Germany, Singapore, Bangladesh.

Presently he is working as Vice –President (Technical Marketing), Hindprakash Lonsen Industries Pvt Ltd, Vatva, Ahmedabad.

He can be reached at dr_nanda_nandan@yahoo.com / nnm@hindprakash.com

2nd NATIONAL CONFERENCE ON “Fashion and Intellectual Property Rights” Held on 26th April, 2011 at NLSIU

Fashion and Law worked in tandem yet again in the environs of NLSIU, Bangalore, to come up with the “2nd National conference on Fashion and IPR” with the joint efforts of Prof Dr Ramakrishna, NLS and Vasant Kothari, Assistant Professor NIFT, Bangalore

Experts and researchers from the MHRD Chair on IPR, NLSIU (Bangalore) coalesced with faculty and students of NIFT, Bangalore and saluted the spirit of IP in the fashion business on the occasion of the World IPR day. The one day conference, held on the 26th of April, proved to be enlightening, enlivening and enjoyable.

The programme was initiated per the Indian traditional way of lighting of the lamp by the dignitaries who graced the occasion. The conference was made doubly special since it coincided with the silver jubilee year of the establishment of NIFT, and its continuous achievement in providing excellence in fashion education.



Lighting of Lamp

The Inaugural address by Prof. Dr. R. Venkatesa Rao, Vice Chancellor, NLSIU, set the tone for the conference. His well crafted address to the stakeholders of IP and fashion called for a strong synergy between both the areas, towards maximizing the identity of the invaluable indigenous Indian arts and the artisans. He also called upon the students and researchers at NLSIU to address IP with a futuristic perspective, such that it evolves as a catalyst to the creative minds for which design becomes livelihood. The enthusiastic response and

appreciation received on his address, was an indication of the excellent connect that his thoughts made with the audience.

Dr. Pinaki Ghosh, Principal IP officer, Infosys, paved way to explore the future of IP in the fashion business. His address to mark the World IPR day was laced with interesting anecdotes on the evolution and elaboration of Intellectual property, and its continuous synergy with design.



(From L to R) *Mr. Nishant Kewalramani, Dr Pinaki Ghosh, Prof. R. Venkata Rao, Dr. Nidhi L. Sarda & Vasant Kothari*

The technical session which followed a short tea break turned out to be a confluence of ideas, discussions, and interactions. The first session saw *Mr. Nishant Kewal Ramani, Portfolio manager, Brainleague IP services*, breaking through and challenging the common conception of fashion and trademarks. *Mr. Kewalramani's* experience and indepth knowledge shone throughout his address on *Fashion and Patent-design law*. Through the use of cases, and with the help of a very interactive audience, he presented the concept of patents and design registrations as effective tools for IP protection. His thoughts were lapped up by the audience, and the enthusiastic discussions that followed stood proof for his very effective presentation.

Ms. Gargi Chakrabarti, Researcher, MHRD Chair on IPR, threw light on the coalition of GI and the fashion industry. Her address was spaced with well researched data on the GIs related to the fashion and textile industry. *Ms. Chakrabarti* also effectively pointed out the way forward for fashion products through the post GI phase, such that the stakeholders get the effective benefits of IP protection.



Mr. Vasant Kothari Presenting Paper during Conference

Her address was followed by an exploration on “Fair use and fashion education” by *Ms. Vibhavari Kumar, Associate professor* and *Ms. Nithya Venkataraman, Assistant professor, NIFT, Bangalore*. They brought to desk their experience in the pedagogy of fashion education, and interfaced the various mechanisms and tools used for disseminating fashion, with the IP of Copyrights and the purview of Fair use. Their presentation was supported by visuals, images and explanations that make way for fashion education for NIFT students and these were observed and discussed with a lot of interest by the student community across both streams present in the audience.

The interpretation for fashion and IP was continued by *Mr. Vasant Kothari, Assistant professor, NIFT*, who was also a co-organizer for the conference. His presentation on the “Importance of certification mark in textiles” elaborated on the huge scope of certification marks on the branding and value addition for textile products. His well thought out and researched details on various certification marks specific to the industry turned to be an extremely informative session for the audience.

The final session continued on the thread of Copyrights in fashion products. *Mr. Satyadeep Singh, Researcher, MHRD chair on IPR* presented his concepts of the “Fashion of copying fashion” with respect to the copyright and design laws across various countries. His acumen for research shone through his presentation, which explored the nature of IP laws on a global platform and its scope across the fashion business.

The conference had enthusiastic student participation through the posters displayed and presented on IP and Fashion. The range included Copyrights and fashion,

GIs in Indian textiles, Cyber squatting, Handloom marks etc. The posters were evaluated by *Prof. Shankar Reddy, NLSIU* and *Dr. Nidhi L. Sharda, Associate Professor, NIFT*. Three posters were awarded according to subject content, research and uniqueness.

The conference ended with a vote of thanks By *Mr. Satyadeep Singh, Researcher, NLSIU*. The panel of speakers as well as the audience members reinforced their commitment for IP awareness in the fashion business.

“The textile industry needs to be Dabbang; Banish Negative thoughts and think big,” says retail magnet Kishore Biyani at InFashion 2011



Mumbai, March 17, 2011: The first edition of the magnum opus InFashion 2011 ended on optimism, dynamism and fresh thinking of the retail visionary Kishore Biyani. In a fitting finale to the three day event the retail guru enthralled the textile fraternity. In an engaging tete-a-tete with Mihir Bhatt, Chief of Bureau, Zee Business Biyani elucidated how he was forced to become a retailer upon repeated rejection from the multi brand retailers. He observed that the fashion industry was not sexy enough to attract the consumers to come and buy. “We will be the first 1 billion fashion company In India,” declared Biyani amongst a thundering applause from the audience.

Going further he urged the textile industry to think big. “Small was beautiful, some time ago. But now it’s god to be medium and large,” he claimed. The textile industry has all the ingredients to become the best industry in the world if they got together, improved the speed of delivery and worked on mind to market. Speaking on government support Biyani termed it the failure of the industry in presenting a clear and rounded picture to the government. China has raced ahead of us in garment manufacturing capabilities and soon Bangladesh will if we don’t act now, he warned. In typical Biyani style the founder of Future Group spoke of how he missed the simplicity of travel by Saurashtra Express and his aversion for the business suit.

Earlier in the day Infashion 2011 saw a cross section of eminent personalities from the fashion communications and research fields converge to discuss innovation in textiles. The session was moderated by Somesh Singh, JD, IAM, who emphasized the fact that innovation is not about the next big technology but about bringing a change in the lives of the end consumers. Urging the textile fraternity to be agents of change Singh make a relevant observation of the best practices being the Next Practises. Citing some poignant innovations Singh spoke of the manikin Charlie which is a manikin with a built in temperature regulatory technology. Water proof swimsuits that help athletes perform better, bullet proof vests made of fibres that are woven tighter so as to reduce impact by bullets or blade and color changing sarees were some other innovations he cited.

Taking the innovation debate further was Professor Jhala, Advisor, Plasma Textile applications, FCIPT, Institute of Plasma Research. He detailed the developments India has made in terms of plasma research for helping the textile industry. Prof Jhala also spoke about the use of the technology for processing Angora fabric and how his organization was able to make the entire process more sustainable and eco-friendly. Adding another interesting spin to the innovation debate was Prasanjit Kundu, Design Head, Dhama Innovations. He elaborated on the ClimaCon which is a range of temperature controlled apparel. The temperatures can be manipulated from 4-44 oc. Kundu shared that his organization is looking at sectors like armed forces and health services to make the innovation reach the common man. Kundu advised the upcoming generation to think of ideas and their conversion into practical marketable solutions.

The first two-days of InFashion 2011 saw power-packed discussions and brainstorming on various issues and concerns faced by the textile fraternity. Innovation was the key word. The panelists and speakers emphasized the importance of being innovative in the business model in order to survive and compete on the global market.

For further information please contact

Perfect Relations
Namrata Aswani – 9920710261
Kapil Kulkarni - 9820203787

May-June 2011

Mr Atul Bhagwati receives 'Friend of Vietnam' award

"A leader is one who sees more than others see, who sees farther than others see, and who sees before others see" - a quote that very aptly fits Mr Atul Bhagwati, Chairman Emeritus, A.T.E. Enterprises Private Limited, who was conferred the 'Friend of Vietnam' award, at an Indo - Vietnamese function held on 3 June 2011.

The award was in recognition of the pivotal role played by Mr Bhagwati over the years in the promotion of bilateral relations between India and Vietnam through the Indo-Vietnamese Chamber of Commerce & Industry (IVCCI) and was presented jointly by Indian Merchants' Chamber (IMC) and IVCCI. According to the Citation of the award, "Two decades ago, when nobody was talking about Vietnam, it was Mr Bhagwati who got together a few Mafatlal Group of Companies as founder members to promote Indo-Vietnamese Chamber of



Mr Nguyen Thanh Tan, H. E. Vietnamese Ambassador to India felicitating Mr Atul Bhagwati (3rd from left), in the presence of Mr Niranjan Hiranandani, MD - Hiranandani Group of Companies and Mrs Nalini Bhagwati w/o Mr Atul Bhagwati.

Commerce & Industry (IVCCI). It was his foresightedness that he took an initiative to set-up this bilateral Chamber, which has since played a major role in enhancing trade and investment relations between India & Vietnam. Bilateral trade between India and Vietnam during this period has increased several fold from just \$ 100 million to \$ 2.8 billion."

The award was presented to Mr Atul Bhagwati at the hands of Mr Nguyen Thanh Tan, H. E. Vietnamese Ambassador to India.

NITRA offers Career-enhancing Distance Learning Programs for Textile & Apparel Industry Professionals under ISDS, GoI

The Indian textile & apparel industry is growing at a rapid pace and is expected to create 10 million job opportunities in the next 10 years. The size of the industry is expected to reach US\$ 220 billion by 2020, out of which export share shall be US\$ 80 billion while the rest will be domestic consumption.

The growth of this industry is likely to attract large FDI inflows in the country especially in the apparel sector. India is being seen as one of the most preferred sourcing hub by the leading overseas buyers such as GAP, J. C. Penny, Walmart, Marks & Spencer etc. Going by its long association with the textile & apparel industry, NITRA has realized that today's working executives are left with no spare time for self development after meeting tight office deadlines and shouldering responsibilities of domestic chore. Keeping that in mind, the career enhancing distance learning programs are launched. Contact classes and lab-based demonstrations are held on two Sundays in a month and elaborate study material is provided for self-study at his/her own pace. It is a matter of great satisfaction that a large number of working executives, who have already undergone NITRA DLP programs, have found the programs very useful for further advancement in their career. To address this acute problem of professional stagnancy for working executives, in the academic session 2011-12 NITRA offers 4 industry oriented customized programs on distance learning basis in addition to 8 programs that are run on full-time mode. The programs cover today's most happening areas such as textiles & apparel manufacturing, textiles & apparel designing, quality control, finishing, merchandising, and machinery maintenance. The full-time programs are aimed at grooming fresh participants whilst career-enhancing distance-learning programs would provide unique opportunity for working executives for upgrading their knowledge and skills.

Furthermore, realizing the need of trained manpower in this sector, Ministry of Textiles, Govt. of India, in July 2010 has launched "Integrated Skill Development Scheme (ISDS) for the Textiles and Apparel Sector including Jute and Handicrafts" to achieve the targets set out by the Prime Minister of India for skill

development. NITRA is chosen as one of the implementing agencies to impart training in the complete textile value chain starting from textile fibre to fashion. Ministry of Textiles has sanctioned a sum of Rs. 12.57 crore to NITRA for upgrading the infrastructure facilities while the State Govt. of U.P. has given a one time grant of Rs. 5.77 crore under the ASIDE scheme.

For further details contact,

NITRA

Sector - 23, Raj Nagar, Ghaziabad- 201 002

Phone: 0120 - 2783090/094/095/334/

586/592/638, 2786434/451

Fax: 0120 - 2783596,

E-mail: mail@ nitratextile.org

Website: nitratextile.org



MOU signed between ICT and BTRA

On 17th June 2011, MOU was signed between Institute of Chemical Technology (ICT) and Bombay Textile Research Association (BTRA) by Prof. (Dr). G.D. Yadav, Director (Vice Chancellor), ICT and Dr. A.N. Desai, Director, BTRA, in presence of Dr. Nadiger, Prof. Adivarekar and Prof. Shukla.

The areas of collaboration includes:

- Post graduate and Doctoral research Program

- Joint Training programs
- Joint Seminars/Conference
- Collaborative R&D projects
- Joint Consultancy program to the textile Industry
- Summer fellowships for UG students
- Training of non teaching staff in use of modern equipments

ICT has already signed Technological cooperation agreement with DyStar India Pvt. Ltd. Almost a year ago and looking forward to sign similar MOU's with Textile Committee and WRA (Wool Research Association). We are sure with such collaborations, all the institutions involved will build on their strengths, and Industry as well as all the stake holders including students will be benefited immensely.



L-R : Prof. S. R. Shukla, Prof. G. D. Yadav, Dr. A.N. Desai, Dr. Nadiger, Prof. M. D. Teli, Prof. R. V. Adivarekar, Dr. Sujata Pariti.

ADVERTISEMENT INDEX

| | | | |
|------------------------------------|-------------|--------------------------------------|------------|
| Air Maaster Industrial Technolozis | A-4 | Lenzing AG - India Branch | A-1 |
| A.T.E. Enterprises Pvt. Ltd. | A-13 | Oerlikon Neumag | A-5 |
| All India Textile Conference | A-6 | Orbitz Corporate & Leisure Travels | A-14 |
| Aspire Chemicals Pvt. Ltd. | A-15 | Paramount Instruments Pvt. Ltd. | Cover - II |
| Bekaert Carding Solutions | A-18 | Precision Rubber Ind. Pvt. Ltd. | A-19 |
| CHT (India) Limited | A-11 | Premier Colorscan Instruments P. Ltd | A -10 |
| Dornier | A-17 | Reliance Industries Ltd. | Cover - I |
| Forbes Marshall | A-3 | Rieter India Pvt. Ltd. | A-9 |
| India ITME 2012 | A-8 | Unitech Techmech | Cover - IV |
| ITMA 2011 | A-12 | Veejay Lakshmi Engg. Works Ltd. | A-7 |
| Kothari Textile Industries | P-41 | Viswaat Chemicals Ltd. | A-18 |
| Lakshmi Machine Works Ltd. | Cover - III | World Traders Mfg. Pvt. Ltd. | A-2 |



TEXTECHNO at the Techtextil 2011 in Frankfurt

At the Techtextil 2011, in Frankfurt, Germany, TEXTECHNO Herbert Stein GmbH & Co. KG, the experts for quality control systems, will be present to introduce new testing instruments for industrial fibres, yarns and fabrics.

TEXTECHNO will introduce the new **FAVIMAT+ AIROBOT2**, an automatic single-fibre testing system including following outstanding features:

- first and only tester to combine six test methods in one instrument, for the determination of the following fibre properties:
 - linear density,
 - tensile properties
 - mechanical crimp properties (crimp percent, removal force and stability)
 - geometrical crimp structure
 - fibre-to-metal friction
 - bending stiffness
- High-resolution force measuring system (1 mN),
- High-resolution elongation measuring system (0.1 mm),
- Wide variety of testable fibres, including Aramide, UHMPE, Glass and Carbon fibres,
- Short-fibre testing (down to 3 mm fibre length),
- Software for cyclic load, relaxation and creep tests,
- in combination with AIROBOT2: fully automatic testing of up to 500 fibres (tensionless storage).

A further highlight is the new automatic drapability tester DRAPETEST. This instrument allows to automatically characterize drapability and the formation of defects during draping and forming. The tester combines the measurement of the force, which is required for forming, with an optical analysis of small-scale defects such as gaps and curls by means of image analysis. An optional sensor can determine large-scale defects such as wrinkles.

Further outstanding Textechno products for testing industrial fibres and yarns are

- **DYNAFIL ME** dynamic shrinkage tester of all kinds of yarns,
- **STATIMAT 4U** Automatic Linear Density, Twist and Tensile Tester for high-tenacity yarns,
- **STATIGRAPH L** Semi-automatic tensile tester for yarns and fabrics,
- **HELFIS** Semi-automatic single fibre shrinkage tester.

You will find TEXTECHNO as well as the Hochschule Niederrhein (University of Applied Sciences) in Hall 3.1, booth 39.

TEXTECHNO at the Techtextil 2011 in Frankfurt

Contact:

M/S. WORLD TRADERS MFG. CO.

1413, Maker Chambers V, 13th floor, Nariman Point,

Mumbai - 400 021

Phone: 022- 22843423/ 22872935/ 22833453/ 22833458

Fax: 022 - 22872534/22833457

E-Mail: info@wtmcindia.com/wtmceeil@gmail.com

Institution of Engineers (India)

Karnataka State Centre, Bangalore

in Association with

Govt. SKSJ Technological Institute Alumni Association



**24th National Convention of Textile Engineers on
"Textile & Apparel Industry : Contemporary
Issues to Address in Coming Years"
On 19th & 20th Aug. 2011**

INDIA
Knit Show

Date: 06-August '11 to 08-August '11

Knit Show – 2011 is a window to the world of accessories, machineries & the opportunities they present. It is a one of a kind event, being the first trade show to exclusively showcase fashion accessories. It offers a meeting point & market place for the industry in its 8th consecutive year.

Venue: Velan Hotel Fair Ground,
Tiruppur, Tamil Nadu, India

International Conference on Textiles—A Decade ahead

Date: 09-10th September, 2011

Venue: PHD House, New Delhi

Organizer: North India Section of The Textile Institute and Department of Textile Technology, IIT, Delhi

Contact: Dr. V.K. Kothari, Professor
Department of textile Technology,
Indian Institute of Technology, Hauz Khas,
New Delhi – 110 016

Tel.: 011-26591407, 011-32035075 (R)

E-mail: kotharivk@gmail.com

India International Yarn Exhibition

Date: 09-SEP-11 to 11-SEP-11

India International Yarn Exhibition - Yarnex 2011 is the only sourcing event of its kind to be held in the textile hub of South India. Yarnex 2011 will bring together under one roof the manufacturers of yarns, both natural and man-made fiber types, from across the country and overseas. The show being strictly for trade visitors only, allows companies to interact and conduct business in a non-cluttered and extremely business-like environment. Yarnex 2011 comes from the house of S S Textile Media Pvt. Ltd., organizers of the Fabrics & Accessories Trade Show which successfully completed its 7th year in June 2010 at Bangalore.

Venue: IKF complex, Tiruppur, Tamil Nadu, India

The India International Textile Show

Date: 19-Apr.11 to 16-Jan.12

The India International Textile Show is a unique online *international trade show* showcasing outstanding companies from the entire Indian textile and clothing value chain. Supported by CITI and its member associations, it is the most cost-effective method to increase brand awareness, establish new markets, sign new contracts and reach designers and manufacturers in India and worldwide.

Venue: TBA, New Delhi, Delhi, India

67th All India Textile Conference

Theme: "Textiles & Clothing –
Emerging Global Scenario"

Date: 04 & 05th February 2012

Venue: Habbitat World, India Habitat Centre,
Lodhi Road, New Delhi –

Organizer: The Textile Association (India) – Delhi Unit

Contact: Mr. Ashok Juneja, Conference Chairman,
Mr. R. Dudeja, Conference Secretary
The Textile Association (India) – Delhi Unit

401, Gagan Deep, 12, Rajendra Place,
New Delhi – 110 008 (India)

Tel.: +91 11 2575 0224, *Fax:* +91 11 2573 6456

E-mail: taidel@bol.net.in

Website: <http://www.tai-delhi.org>

INDIA ITME 2012 – 9th International Textile Machinery Exhibition

Date: 02-07th December 2012

Venue: Bombay Exhibition Centre, Western Express
Highway, Goregaon (E), Mumbai, India

Contact: Executive Director

India International Textile
Machinery Exhibitions Society

76, Mittal Tower, B Wing, 7th Floor,

Nariman Point, Mumbai – 400 021 India

Tel.: +91 22-2202 0032, 2282 8138, 2285 1579

Fax: +91 22-2285 1578

E-mail: contactat@india-itme.com

Website: <http://www.india-itme.com>

7th International Conference on Apparel & Home Textiles

Theme: "Make Competition Irrelevant"

Date: 30th September & 01st October, 2011

Venue: Habbitat World, India Habitat Centre,
Lodhi Road, New Delhi –

Organizer: Okhla Garment and Cluster

Contact: Mr. R.C. Kesar,

Conference Chairman – 9810091812

Mr. M.K. Mehra,

Conference Advisor – 9868200116

Okhla Garment and Textile Cluster

Y-29, Okhla Industrial Area, Phase II,
New Delhi 110 020 India

Tel.: +91 11 41609550, *Fax:* 0+91 11 26383532

E-mail: ogtc@airtelmail.in, ogtc@rediffmail.com

Website: www.ogtc.in

ABROAD
ITMA 2011 – International Exhibition of Textile and Garment Machinery

Date: 22 to 29th September, 2011

Venue: Fira de Barcelona Gran Via, Spain,

Organizer: CEMATEX

PO Box 248, Newcastle upon Tyne,
NE7 7WY, United Kingdom

Tel.: +44 7967 477305,

Website: <http://www.itma.com>

11th Asian Textile Conference (ATC-11)

Theme: Knowledge Convergence in Textiles for
Human & Nature

Date: 01 to 04 November, 2011

Venue: Daegu Exhibition and Convention Center
(EXCO), Daegu, Korea

Organizer: Federation of Asian Professional Textile
Association (FAPTA)

Contact: Prof. Jun Young LEE

Tel.: +82 31 2907319, *Fax:* +82 31 290 7272

E-mail: info@atc11.org, jylee@skku.edu

Website: <http://www.atc11.org>

Every effort is made to ensure that the information given is correct. You are however, advised to re-check the dates with the organizers, for any change in schedule, before finalizing your travel plans.